

**SIEMENS**

# Microcomputer Components

8-Bit CMOS Microcontroller

**C517A**

Data Sheet 01.99

<http://www.siemens.com/semiconductor/>

<b>C517A Data Sheet</b>		
<b>Revision History :</b>		01.99
<b>Previous Releases :</b>		08.97 (Original Version)
Page (previous version)	Page (new version)	Subjects (changes since last revision)
All sections	All sections	$V_{CC}$ is changed to $V_{DD}$ and $I_{CC}$ is changed to $I_{DD}$ .
2	2	"with wake-up capability through INT0 pin" is removed.
2	2	P-LCC-84 package is added under the feature list.
2 to 3	2	Table 1; deleted and replaced by "Ordering Information" paragraph "Additional Literature";deleted.
5	5	Figure 4; added.
5	6	Table 1; modified, column "P-LCC-84" is added.
47	50	"or by a short low pulse at pin P3.2/INT0" is removed.
48	50	"Short low pulse at pin P3.2/INT0" is removed.
49	52	"Absolute Maximum Ratings" is changed to tabular form.
49	52	Fifth line; "During overload conditions ..." changed to "During absolute maximum rating conditons ...".
49	52	"Operating Conditions" is added.
50	53	" $V_{CC} = 5\text{ V} + 10\% \dots$ " is replaced by "(Operating Conditions apply)".
51	54	Notes (7); modified.
53	56	" $V_{CC} = 5\text{ V} + 10\% \dots$ " is replaced by "(Operating Conditions apply)".
55	58	" $V_{CC} = 5\text{ V} + 10\% \dots$ " is replaced by "(Operating Conditions apply)".
62	65	First line; "C517A-1RM" is replaced by "C517A-4RM/4RN"
-	69	Figure 38; added.

### Edition 01.99

This edition was realized using the software system FrameMaker®.

Published by : Siemens AG, Semiconductor Group, Product Definition 8-Bit Microcontroller Components, Balanstraße 73, D-81541 München .

© Siemens AG 01.99,. All Rights Reserved.

"Enhanced Hooks Technology" is a trademark and patent of Metalink Corporation, licensed to Siemens.

As far as patents or other rights of third parties are concerned, liability is only assumed for components, not for applications, processes and circuits implemented within components or assemblies.

The information describes the type of component and shall not be considered as assured characteristics.

Terms of delivery and rights to change design reserved.

For questions on technology, delivery and prices please contact the Semiconductor Group Offices in Germany or the Siemens Companies and Representatives worldwide.

Due to technical requirements components may contain dangerous substances. For information on the type in question please contact your nearest Siemens Office, Components Group.

Siemens AG is an approved CECC manufacturer.

### Packing

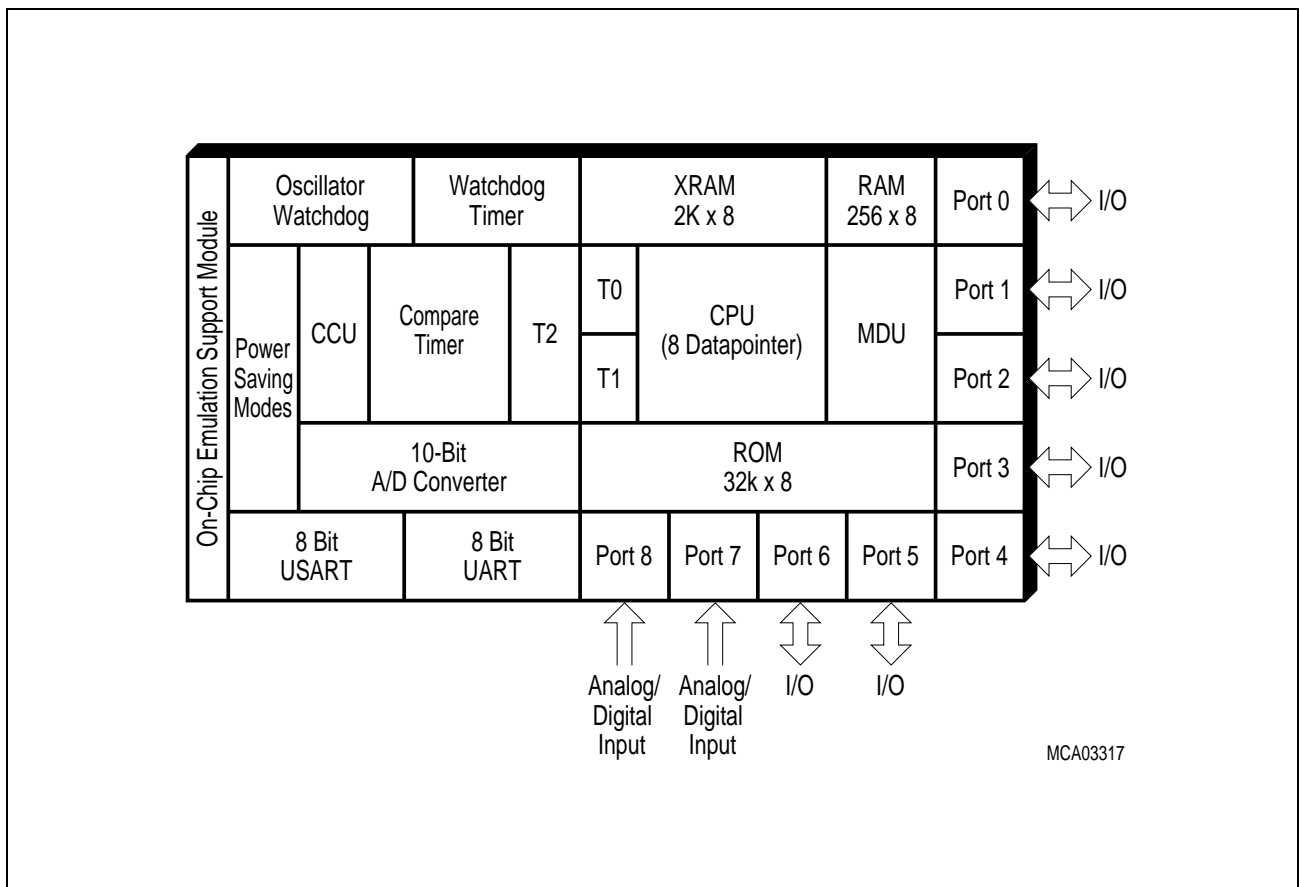
Please use the recycling operators known to you. We can also help you - get in touch with your nearest sales office. By agreement we will take packing material back, if it is sorted. You must bear the costs of transport.

For packing material that is returned to us unsorted or which we are not obliged to accept, we shall have ti invoice you for any costs incurred.

### Advance Information

- Full upward compatibility with SAB 80C517A/83C517A-5
- Up to 24 MHz external operating frequency
  - 500 ns instruction cycle at 24 MHz operation
- Superset of the 8051 architecture with 8 datapointers
- On-chip emulation support logic (Enhanced Hooks Technology™)
- 32K byte on-chip ROM (with optional ROM protection)
  - alternatively up to 64K byte external program memory
- Up to 64K byte external data memory
- 256 byte on-chip RAM
- Additional 2K byte on-chip RAM (XRAM)
- Seven 8-bit parallel I/O ports
- Two input ports for analog/digital input

(further features are on next page)



**Figure 1**  
**C517A Functional Units**

Features (continued) :

- Two full duplex serial interfaces (USART)
  - 4 operating modes, fixed or variable baud rates
  - programmable baud rate generators
- Four 16-bit timer/counters
  - Timer 0 / 1 (C501 compatible)
  - Timer 2 for 16-bit reload, compare, or capture functions
  - Compare timer for compare/capture functions
- Powerful 16-bit compare/capture unit (CCU) with up to 21 high-speed or PWM output channels and 5 capture inputs
- 10-bit A/D converter
  - 12 multiplexed analog inputs
  - Built-in self calibration
- Extended watchdog facilities
  - 15-bit programmable watchdog timer
  - Oscillator watchdog
- Power saving modes
  - Slow down mode
  - Idle mode (can be combined with slow down mode)
  - Software power-down mode
  - Hardware power-down mode
- 17 interrupt sources (7 external, 10 internal) selectable at 4 priority levels
- P-MQFP-100 and P-LCC-84 packages
- Temperature Ranges :

SAB-C517A	$T_A = 0$ to $70$ °C
SAF-C517A	$T_A = -40$ to $85$ °C
SAH-C517A	$T_A = -40$ to $110$ °C

### Ordering Information

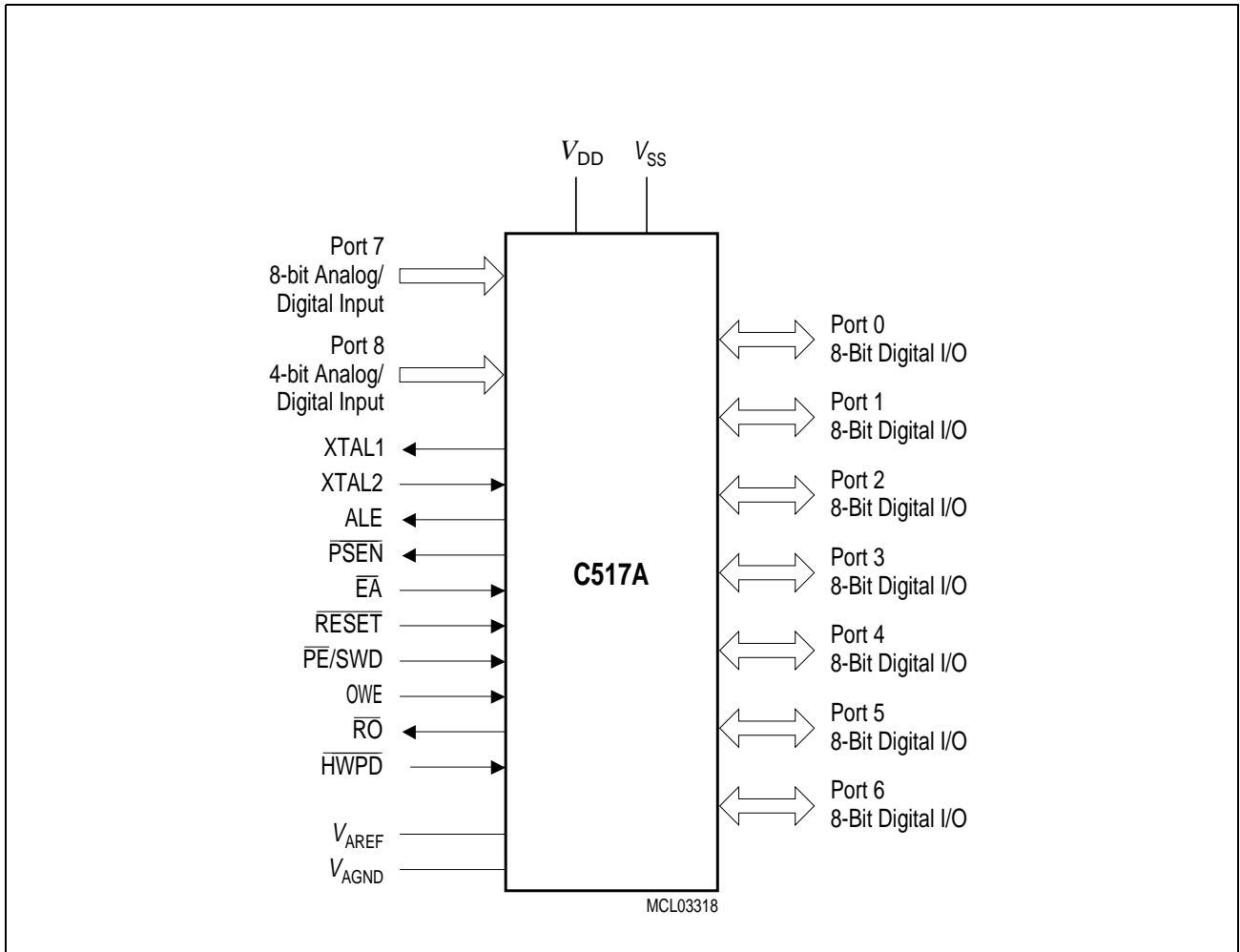
The ordering code for Siemens microcontrollers provides an exact reference to the required product. This ordering code identifies:

- the derivative itself, i.e. its function set
- the specified temperature range
- the package and the type of delivery.

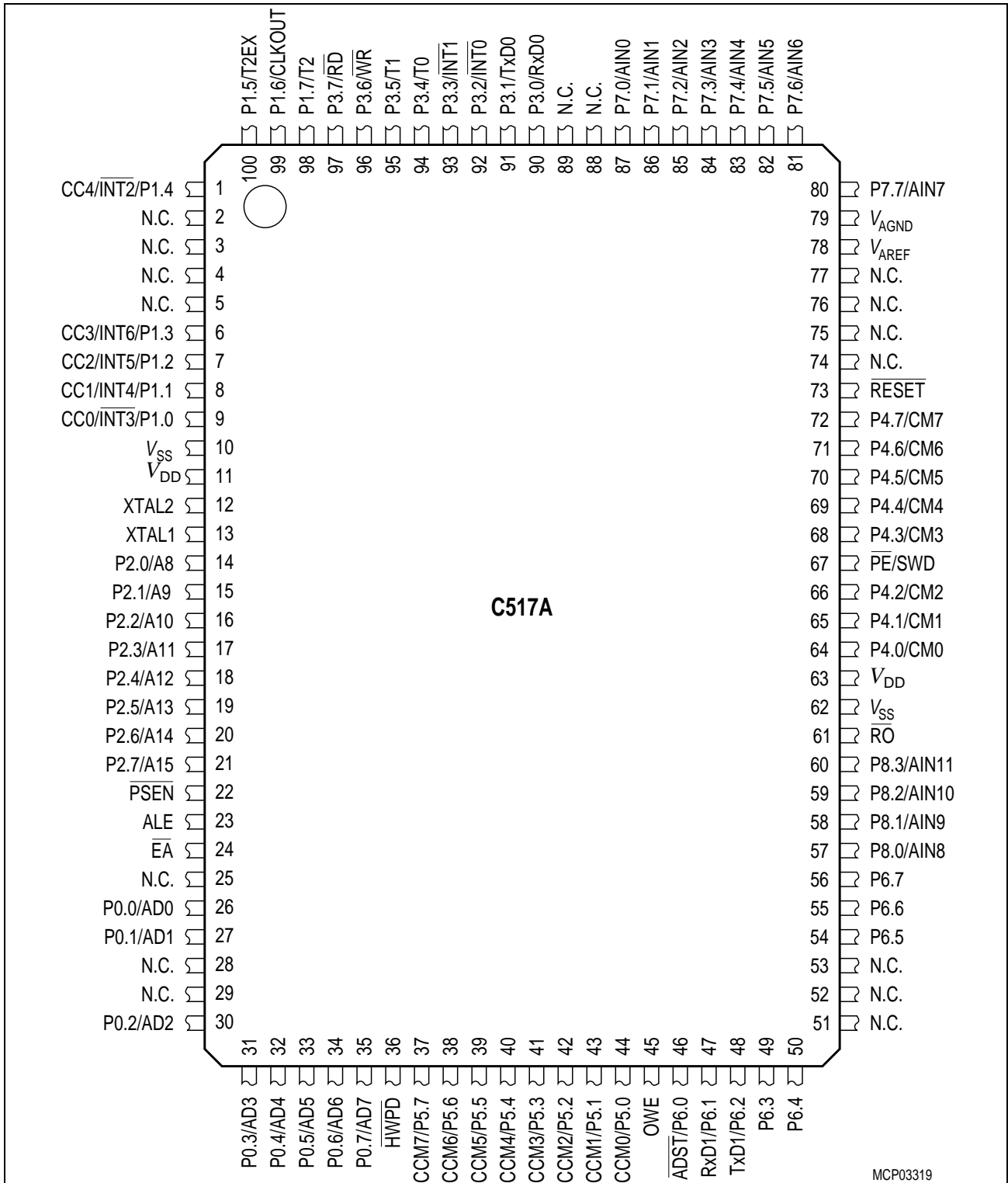
For the available ordering codes for the C517A please refer to the

„**Product Information Microcontrollers**“, which summarizes all available microcontroller variants.

Note: The ordering codes for the Mask-ROM versions are defined for each product after verification of the respective ROM code.



**Figure 2**  
**Logic Symbol**



**Figure 3**  
**Pin Configuration P-MQFP-100 Package (Top View)**

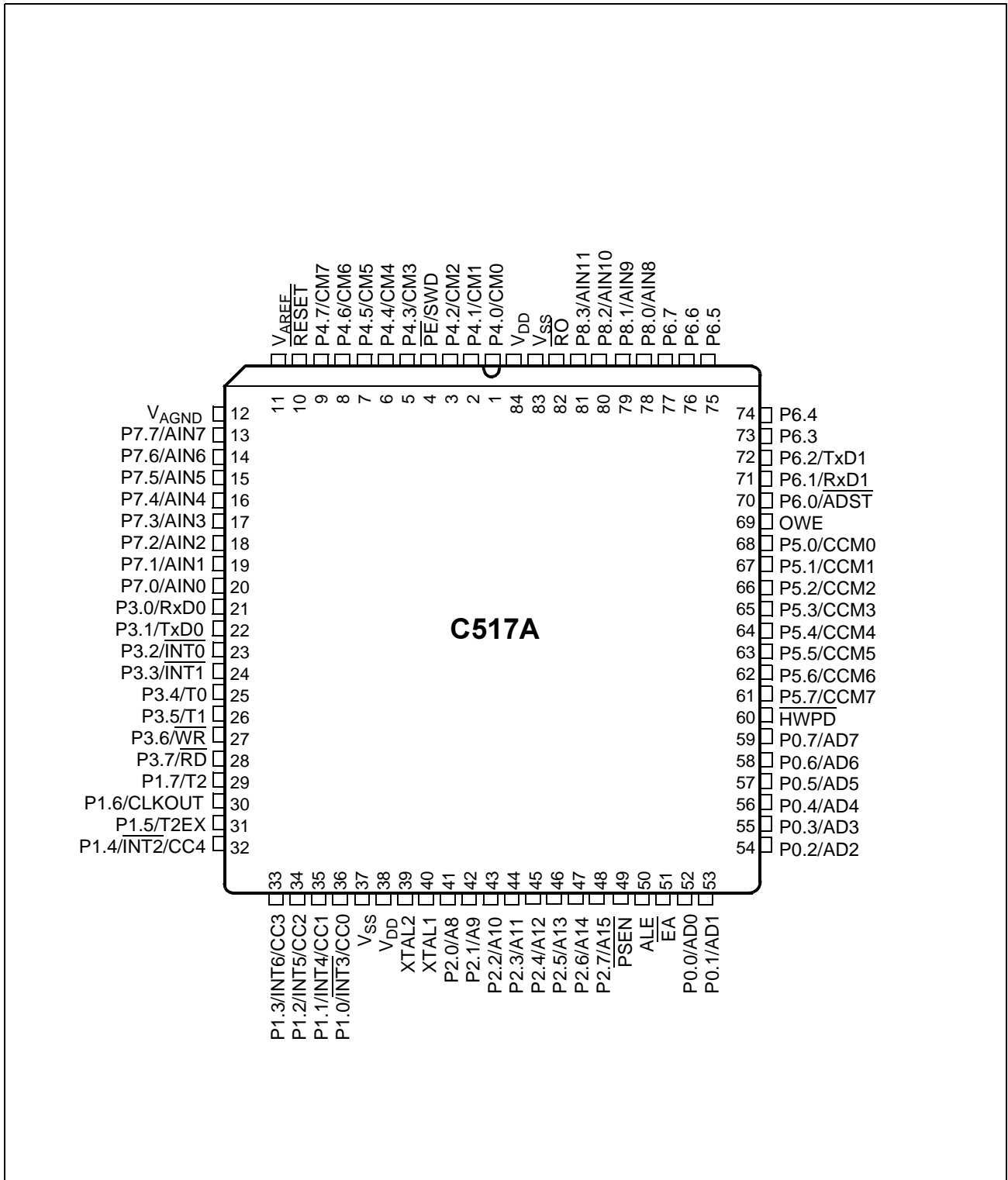


Figure 4  
Pin Configuration P-LCC-84 Package (Top View)

**Table 1**  
**Pin Definitions and Functions**

Symbol	Pin Number		I/O*)	Function
	P-MQFP-100	P-LCC-84		
P1.0 - P1.7	9 - 6, 1, 100 - 98	36 - 29	I/O	<p><b>Port 1</b> is an 8-bit quasi-bidirectional I/O port with internal pullup resistors. Port 1 pins that have 1's written to them are pulled high by the internal pullup resistors, and in that state can be used as inputs. As inputs, port 1 pins being externally pulled low will source current (<math>I_{IL}</math>, in the DC characteristics) because of the internal pullup resistors. The port is used for the low-order address byte during program verification. Port 1 also contains the interrupt, timer, clock, capture and compare pins that are used by various options. The output latch corresponding to a secondary function must be programmed to a one (1) for that function to operate (except when used for the compare functions). The secondary functions are assigned to the port 1 pins as follows :</p>
	9	36		P1.0 / $\overline{INT3}$ / CC0    Interrupt 3 input / compare 0 output / capture 0 input
	8	35		P1.1 / INT4 / CC1    Interrupt 4 input / compare 1 output / capture 1 input
	7	34		P1.2 / INT5 / CC2    Interrupt 5 input / compare 2 output / capture 2 input
	6	33		P1.3 / INT6 / CC3    Interrupt 6 input / compare 3 output / capture 3 input
	1	32		P1.4 / $\overline{INT2}$ / CC4    Interrupt 2 input / compare 4 output / capture 4 input
	100	31		P1.5 / T2EX    Timer 2 external reload / trigger input
	99	30		P1.6 / CLKOUT    System clock output
	98	29		P1.7 / T2    Counter 2 input

\*) I = Input,  
O = Output



**Table 1**  
**Pin Definitions and Functions (cont'd)**

Symbol	Pin Number		I/O*)	Function
	P-MQFP-100	P-LCC-84		
V <sub>SS</sub>	10, 62	37, 83	–	<b>Ground (0V)</b> during normal, idle, and power down operation.
V <sub>DD</sub>	11, 63	38, 84	–	<b>Supply voltage</b> during normal, idle, and power down mode.
XTAL2	12	39	–	<b>XTAL2</b> is the input to the inverting oscillator amplifier and input to the internal clock generator circuits. To drive the device from an external clock source, XTAL2 should be driven, while XTAL1 is left unconnected. Minimum and maximum high and low times as well as rise/fall times specified in the AC characteristics must be observed.
XTAL1	13	40	–	<b>XTAL1</b> is the output of the inverting oscillator amplifier. This pin is used for the oscillator operation with crystal or ceramic resonator.
P2.0 - P2.7	14 - 21	41 - 48	I/O	<b>Port 2</b> is an 8-bit quasi-bidirectional I/O port with internal pullup resistors. Port 2 pins that have 1's written to them are pulled high by the internal pullup resistors, and in that state can be used as inputs. As inputs, port 2 pins being externally pulled low will source current ( $I_{IL}$ , in the DC characteristics) because of the internal pullup resistors. Port 2 emits the high-order address byte during fetches from external program memory and during accesses to external data memory that use 16-bit addresses (MOVX @DPTR). In this application it uses strong internal pullup resistors when issuing 1's. During accesses to external data memory that use 8-bit addresses (MOVX @Ri), port 2 issues the contents of the P2 special function register.

\*) I = Input  
O = Output

**Table 1**  
**Pin Definitions and Functions (cont'd)**

Symbol	Pin Number		I/O*)	Function
	P-MQFP-100	P-LCC-84		
$\overline{\text{PSEN}}$	22	49	O	The <b>Program Store Enable</b> output is a control signal that enables the external program memory to the bus during external fetch operations. It is activated every six oscillator periods except during external data memory accesses. The signal remains high during internal program execution.
ALE	23	50	O	The <b>Address Latch enable</b> output is used for latching the address into external memory during normal operation. It is activated every six oscillator periods except during an external data memory access.
$\overline{\text{EA}}$	24	51	I	<b>External Access Enable</b> When held high, the C517A executes instructions from the internal ROM as long as the PC is less than 8000 <sub>H</sub> . When held low, the C517A fetches all instructions from external program memory. For the C517A-L this pin must be tied low. For the C517A-4R, if the device is protected (see section 4.6 in the User Manual) then this pin is only latched during reset.
P0.0 - P0.7	26, 27, 30 - 35	52 - 59	I/O	<b>Port 0</b> is an 8-bit open-drain bidirectional I/O port. Port 0 pins that have 1's written to them float, and in that state can be used as high-impedance inputs. Port 0 is also the multiplexed low-order address and data bus during accesses to external program and data memory. In this application it uses strong internal pullup resistors when issuing 1's. Port 0 also outputs the code bytes during program verification in the C517A-4R. External pullup resistors are required during program verification.

\*) I = Input  
O = Output

**Table 1**  
**Pin Definitions and Functions (cont'd)**

Symbol	Pin Number		I/O*)	Function
	P-MQFP-100	P-LCC-84		
$\overline{\text{HWPD}}$	36	60	I	<b>Hardware Power Down</b> A low level on this pin for the duration of one machine cycle while the oscillator is running resets the C517A. A low level for a longer period will force the part into hardware power down mode with the pins floating. There is no internal pullup resistor connected to this pin.
P5.0 - P5.7	44 - 37	68 - 61	I/O	<b>Port 5</b> is a quasi-bidirectional I/O port with internal pull-up resistors. Port 5 pins that have 1 s written to them are pulled high by the internal pull-up resistors, and in that state can be used as inputs. As inputs, port 5 pins being externally pulled low will source current ( $I_{IL}$ , in the DC characteristics) because of the internal pull-up resistors. This port also serves the alternate function "Concurrent Compare" and "Set/Reset Compare". The secondary functions are assigned to the port 5 pins as follows: CCM0 to CCM7    P5.0 to P5.7 : concurrent compare or Set/Reset lines
OWE	45	69	I	<b>Oscillator Watchdog Enable</b> A high level on this pin enables the oscillator watchdog. When left unconnected this pin is pulled high by a weak internal pull-up resistor. The logic level at OWE should not be changed during normal operation. When held at low level the oscillator watchdog function is turned off. During hardware power down the pullup resistor is switched off.

\*) I = Input  
O = Output

**Table 1**  
**Pin Definitions and Functions (cont'd)**

Symbol	Pin Number		I/O*)	Function
	P-MQFP-100	P-LCC-84		
P6.0 - P6.7	46 - 50, 54 - 56	70 - 77	I/O	<p><b>Port 6</b> is a quasi-bidirectional I/O port with internal pull-up resistors. Port 6 pins that have 1 s written to them are pulled high by the internal pull-up resistors, and in that state can be used as inputs. As inputs, port 6 pins being externally pulled low will source current (<math>I_{IL}</math>, in the DC characteristics) because of the internal pull-up resistors. Port 6 also contains the external A/D converter start control pin and the transmit and receive pins for the serial interface 1. The output latch corresponding to a secondary function must be programmed to a one (1) for that function to operate. The secondary functions are assigned to the pins of port 6, as follows :</p> <p>P6.0 <math>\overline{ADST}</math> external A/D converter start pin</p> <p>P6.1 RxD1 receiver data input of serial interface 1</p> <p>P6.2 TxD1 transmitter data input of serial interface 1</p>
P8.0 - P8.3	57 - 60	78 - 81	I	<p><b>Port 8</b> is a 4-bit unidirectional input port. Port pins can be used for digital input, if voltage levels meet the specified input high/low voltages, and for the higher 4-bit of the multiplexed analog inputs of the A/D converter, simultaneously.</p> <p>P8.0 - P8.3 AIN8 - AIN11 analog input 8 - 11</p>
$\overline{RO}$	61	82	O	<p><b>Reset Output</b> This pin outputs the internally synchronized reset request signal. This signal may be generated by an external hardware reset, a watchdog timer reset or an oscillator watchdog reset. The <math>\overline{RO}</math> output signal is active low.</p>

\*) I = Input  
O = Output

**Table 1**  
**Pin Definitions and Functions (cont'd)**

Symbol	Pin Number		I/O*)	Function
	P-MQFP-100	P-LCC-84		
P4.0 - P4.7	64 - 66, 68 - 72	1 - 3, 5 - 9	I/O	<p><b>Port 4</b>                      is an 8-bit quasi-bidirectional I/O port with internal pull-up resistors. Port 4 pins that have 1's written to them are pulled high by the internal pull-up resistors, and in that state can be used as inputs. As inputs, port 4 pins being externally pulled low will source current (<math>I_{IL}</math>, in the DC characteristics) because of the internal pull-up resistors. Port 4 also serves as alternate compare functions. The output latch corresponding to a secondary function must be programmed to a one (1) for that function to operate. The secondary functions are assigned to the pins of port 4 as follows :</p> <p>P4.0 - P4.7    CM0 - CM7    Compare channel 0 - 7</p>
$\overline{PE}/SWD$	67	4	I	<p><b>Power saving mode enable / Start watchdog timer</b>                      A low level at this pin allows the software to enter the power saving modes (idle mode, slow down mode, and power down mode). In case the low level is also seen during reset, the watchdog timer function is off on default.                      Usage of the software controlled power saving modes is blocked, when this pin is held at high level. A high level during reset performs an automatic start of the watchdog timer immediately after reset.                      When left unconnected this pin is pulled high by a weak internal pull-up resistor. During hardware power down the pullup resistor is switched off.</p>

\*) I = Input  
 O = Output

**Table 1**  
**Pin Definitions and Functions (cont'd)**

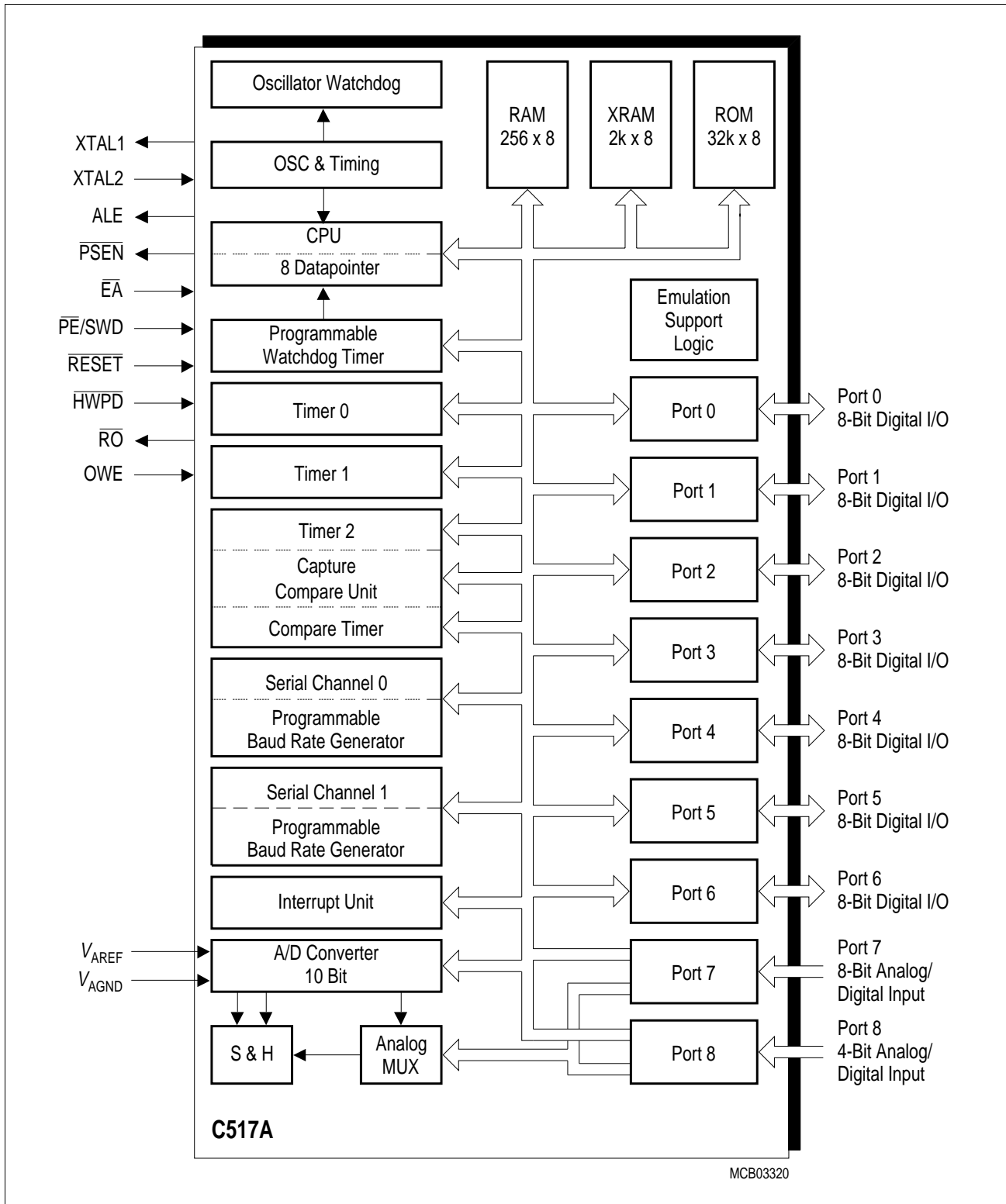
Symbol	Pin Number		I/O*)	Function
	P-MQFP-100	P-LCC-84		
P3.0 - P3.7	90 - 97	21 - 28	I/O	<p><b>Port 3</b> is an 8-bit quasi-bidirectional I/O port with internal pullup resistors. Port 3 pins that have 1's written to them are pulled high by the internal pullup resistors, and in that state can be used as inputs. As inputs, port 3 pins being externally pulled low will source current (<math>I_{IL}</math>, in the DC characteristics) because of the internal pullup resistors. Port 3 also contains the interrupt, timer, serial port and external memory strobe pins that are used by various options. The output latch corresponding to a secondary function must be programmed to a one (1) for that function to operate. The secondary functions are assigned to the pins of port 3, as follows:</p>
	90	21		<p>P3.0 / RxD0 Receiver data input (asynch.) or data input/output (synch.) of serial interface 0</p>
	91	22		<p>P3.1 / TxD0 Transmitter data output (asynch.) or clock output (synch.) of serial interface 0</p>
	92	23		<p>P3.2 / <math>\overline{\text{INT0}}</math> External interrupt 0 input / timer 0 gate control input</p>
	93	24		<p>P3.3 / <math>\overline{\text{INT1}}</math> External interrupt 1 input / timer 1 gate control input</p>
	94	25		<p>P3.4 / T0 Timer 0 counter input</p>
	95	26		<p>P3.5 / T1 Timer 1 counter input</p>
	96	27		<p>P3.6 / <math>\overline{\text{WR}}</math> <math>\overline{\text{WR}}</math> control output; latches the data byte from port 0 into the external data memory</p>
	97	28		<p>P3.7 / <math>\overline{\text{RD}}</math> <math>\overline{\text{RD}}</math> control output; enables the external data memory</p>

\*) I = Input  
O = Output

**Table 1**  
**Pin Definitions and Functions (cont'd)**

Symbol	Pin Number		I/O*)	Function
	P-MQFP-100	P-LCC-84		
$\overline{\text{RESET}}$	73	10	I	<b>RESET</b> A low level on this pin for the duration of two machine cycles while the oscillator is running resets the C517A. A small internal pullup resistor permits power-on reset using only a capacitor connected to $V_{SS}$ .
$V_{\text{AREF}}$	78	11	–	<b>Reference voltage</b> for the A/D converter
$V_{\text{AGND}}$	79	12	–	<b>Reference ground</b> for the A/D converter
P7.0 - P7.7	87 - 80	20-13	I	<b>Port 7</b> is an 8-bit unidirectional input port. Port pins can be used for digital input, if voltage levels meet the specified input high/low voltages, and for the lower 8-bit of the multiplexed analog inputs of the A/D converter, simultaneously. P7.0 - P7.7    AIN0 - AIN7    analog input0 - 7
N.C.	2 - 5, 25, 28, 29, 51 - 53, 74 - 77 88, 89	–	–	<b>Not connected</b> These pins of the P-MQFP-100 package must not be connected.

\*) I = Input  
O = Output



**Figure 5**  
**Block Diagram of the C517A**



## CPU

The C517A is efficient both as a controller and as an arithmetic processor. It has extensive facilities for binary and BCD arithmetic and excels in its bit-handling capabilities. Efficient use of program memory results from an instruction set consisting of 44 % one-byte, 41 % two-byte, and 15% three-byte instructions. With a 12 MHz crystal, 58% of the instructions are executed in 1µs (24 MHz : 500 ns).

### Special Function Register PSW (Address D0<sub>H</sub>)

Reset Value : 00<sub>H</sub>

Bit No.	MSB							LSB	
	D7 <sub>H</sub>	D6 <sub>H</sub>	D5 <sub>H</sub>	D4 <sub>H</sub>	D3 <sub>H</sub>	D2 <sub>H</sub>	D1 <sub>H</sub>	D0 <sub>H</sub>	
D0 <sub>H</sub>	CY	AC	F0	RS1	RS0	OV	F1	P	PSW

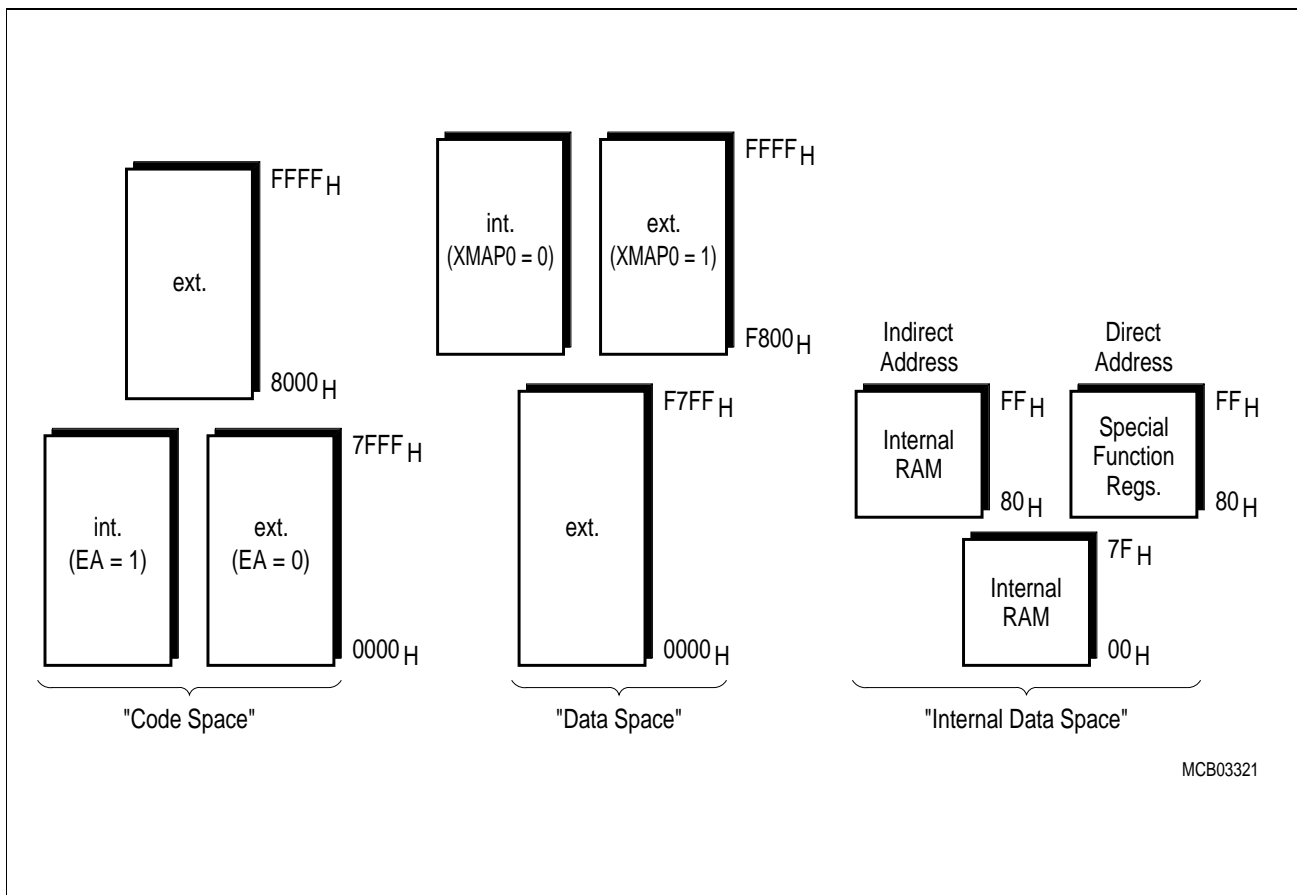
Bit	Function															
CY	Carry Flag Used by arithmetic instruction.															
AC	Auxiliary Carry Flag Used by instructions which execute BCD operations.															
F0	General Purpose Flag															
RS1 RS0	Register Bank select control bits These bits are used to select one of the four register banks.															
	<table border="1" style="width: 100%; border-collapse: collapse;"> <thead> <tr> <th style="text-align: left;">RS1</th> <th style="text-align: left;">RS0</th> <th style="text-align: left;">Function</th> </tr> </thead> <tbody> <tr> <td>0</td> <td>0</td> <td>Bank 0 selected, data address 00<sub>H</sub>-07<sub>H</sub></td> </tr> <tr> <td>0</td> <td>1</td> <td>Bank 1 selected, data address 08<sub>H</sub>-0F<sub>H</sub></td> </tr> <tr> <td>1</td> <td>0</td> <td>Bank 2 selected, data address 10<sub>H</sub>-17<sub>H</sub></td> </tr> <tr> <td>1</td> <td>1</td> <td>Bank 3 selected, data address 18<sub>H</sub>-1F<sub>H</sub></td> </tr> </tbody> </table>	RS1	RS0	Function	0	0	Bank 0 selected, data address 00 <sub>H</sub> -07 <sub>H</sub>	0	1	Bank 1 selected, data address 08 <sub>H</sub> -0F <sub>H</sub>	1	0	Bank 2 selected, data address 10 <sub>H</sub> -17 <sub>H</sub>	1	1	Bank 3 selected, data address 18 <sub>H</sub> -1F <sub>H</sub>
RS1	RS0	Function														
0	0	Bank 0 selected, data address 00 <sub>H</sub> -07 <sub>H</sub>														
0	1	Bank 1 selected, data address 08 <sub>H</sub> -0F <sub>H</sub>														
1	0	Bank 2 selected, data address 10 <sub>H</sub> -17 <sub>H</sub>														
1	1	Bank 3 selected, data address 18 <sub>H</sub> -1F <sub>H</sub>														
OV	Overflow Flag Used by arithmetic instruction.															
F1	General Purpose Flag															
P	Parity Flag Set/cleared by hardware after each instruction to indicate an odd/even number of "one" bits in the accumulator, i.e. even parity.															

**Memory Organization**

The C517A CPU manipulates operands in the following five address spaces:

- up to 64 Kbyte of program memory (32K on-chip program memory for C517A-4R)
- up to 64 Kbyte of external data memory
- 256 bytes of internal data memory
- 2K bytes of internal XRAM data memory
- a 128 byte special function register area

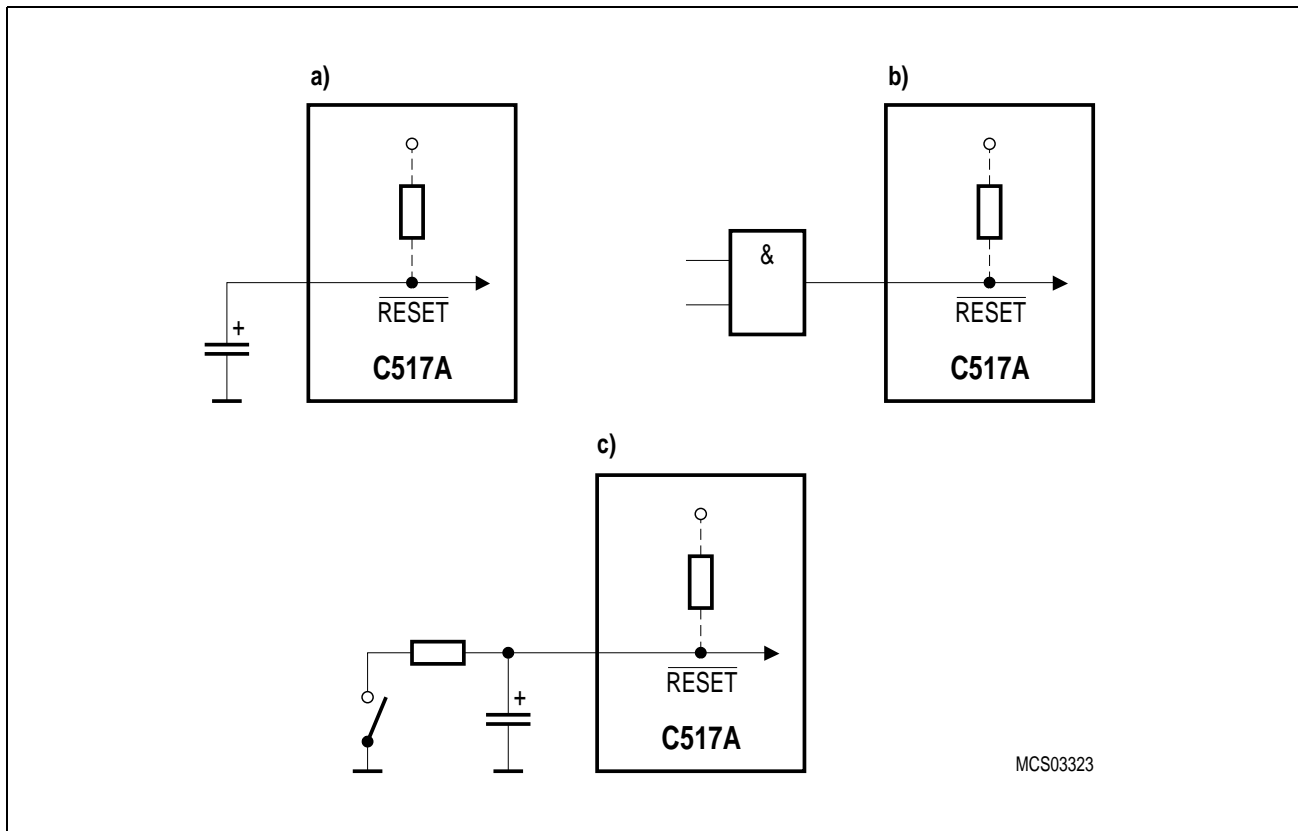
Figure 6 illustrates the memory address spaces of the C517A.



**Figure 6**  
**C517A Memory Map**

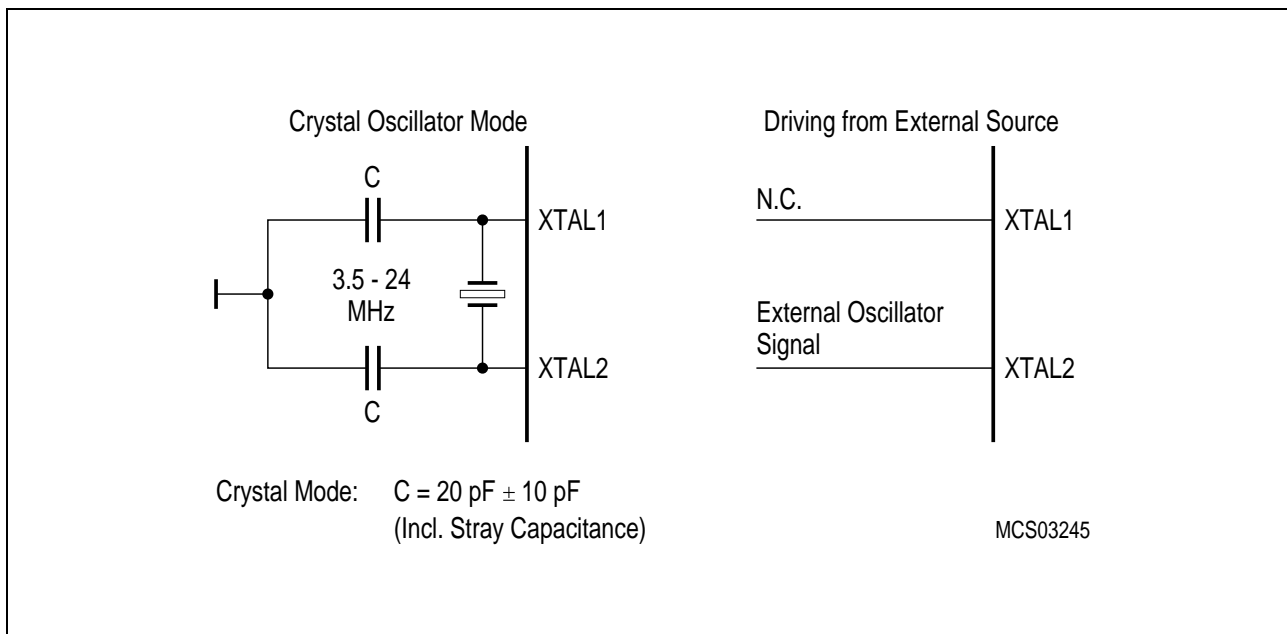
**Reset and System Clock**

The reset input is an active low input at pin  $\overline{\text{RESET}}$ . Since the reset is synchronized internally, the  $\overline{\text{RESET}}$  pin must be held low for at least two machine cycles (24 oscillator periods) while the oscillator is running. A pullup resistor is internally connected to  $V_{DD}$  to allow a power-up reset with an external capacitor only. An automatic reset can be obtained when  $V_{DD}$  is applied by connecting the  $\overline{\text{RESET}}$  pin to  $V_{SS}$  via a capacitor. **Figure 7** shows the possible reset circuitries.



**Figure 7**  
**Reset Circuitries**

Figure 8 shows the recommended oscillator circuitries for crystal and external clock operation.



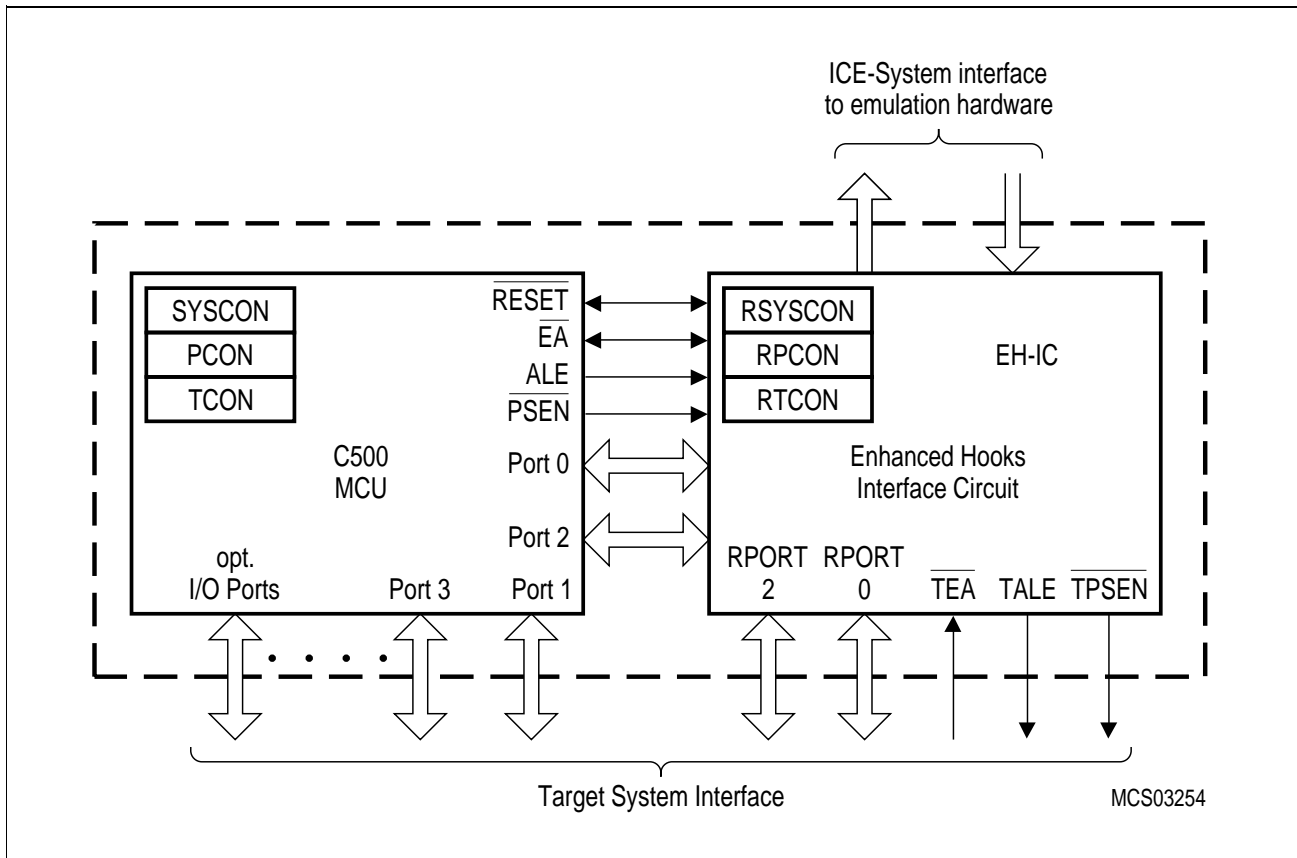
**Figure 8**  
**Recommended Oscillator Circuitries**

**Enhanced Hooks Emulation Concept**

The Enhanced Hooks Emulation Concept of the C500 microcontroller family is a new, innovative way to control the execution of C500 MCUs and to gain extensive information on the internal operation of the controllers. Emulation of on-chip ROM based programs is possible, too.

Each production chip has built-in logic for the support of the Enhanced Hooks Emulation Concept. Therefore, no costly bond-out chips are necessary for emulation. This also ensures that emulation and production chips are identical.

The Enhanced Hooks Technology<sup>TM 1)</sup>, which requires embedded logic in the C500 allows the C500 together with an EH-IC to function similar to a bond-out chip. This simplifies the design and reduces costs of an ICE-system. ICE-systems using an EH-IC and a compatible C500 are able to emulate all operating modes of the different versions of the C500 microcontrollers. This includes emulation of ROM, ROM with code rollover and ROMless modes of operation. It is also able to operate in single step mode and to read the SFRs after a break.



**Figure 9**  
**Basic C500 MCU Enhanced Hooks Concept Configuration**

Port 0, port 2 and some of the control lines of the C500 based MCU are used by Enhanced Hooks Emulation Concept to control the operation of the device during emulation and to transfer informations about the programm execution and data transfer between the external emulation hardware (ICE-system) and the C500 MCU.

1 "Enhanced Hooks Technology" is a trademark and patent of Metalink Corporation licensed to Siemens.

### Special Function Registers

The registers, except the program counter and the four general purpose register banks, reside in the special function register area.

The 94 special function registers (SFRs) in the standard and mapped SFR area include pointers and registers that provide an interface between the CPU and the other on-chip peripherals. All SFRs with addresses where address bits 0-2 are 0 (e

.g. 80<sub>H</sub>, 88<sub>H</sub>, 90<sub>H</sub>, 98<sub>H</sub>, ..., F8<sub>H</sub>, FF<sub>H</sub>) are bitaddressable. The SFRs of the C517A are listed in **table 2** and **table 3**. In **table 2** they are organized in groups which refer to the functional blocks of the C517A. **Table 3** illustrates the contents of the SFRs in numeric order of their addresses.

**Table 2**  
**Special Function Registers - Functional Blocks**

Block	Symbol	Name	Address	Contents after Reset
CPU	ACC	Accumulator	<b>E0H</b> <sup>1)</sup>	00H
	B	B-Register	<b>F0H</b> <sup>1)</sup>	00H
	DPH	Data Pointer, High Byte	83H	00H
	DPL	Data Pointer, Low Byte	82H	00H
	DPSEL	Data Pointer Select Register	92H	XXXX X000B <sup>3)</sup>
	PSW	Program Status Word Register	<b>D0H</b> <sup>1)</sup>	00H
	SP	Stack Pointer	81H	07H
A/D- Converter	ADCON0 <sup>2)</sup>	A/D Converter Control Register 0	<b>D8H</b> <sup>1)</sup>	00H
	ADCON1	A/D Converter Control Register 1	DC <sub>H</sub>	0XXX 0000B <sup>3)</sup>
	ADDATH	A/D Converter Data Register, High Byte	D9 <sub>H</sub>	00H
	ADDATL	A/D Converter Data Register, Low Byte	DA <sub>H</sub>	00XX XXXXB <sup>3)</sup>
Interrupt System	IEN0 <sup>2)</sup>	Interrupt Enable Register 0	<b>A8H</b> <sup>1)</sup>	00H
	IEN1 <sup>2)</sup>	Interrupt Enable Register 1	<b>B8H</b> <sup>1)</sup>	00H
	IEN2	Interrupt Enable Register 2	9A <sub>H</sub>	XX00 00X0B <sup>3)</sup>
	IP0 <sup>2)</sup>	Interrupt Priority Register 0	A9 <sub>H</sub>	00H
	IP1	Interrupt Priority Register 1	B9 <sub>H</sub>	XX00 0000B <sup>3)</sup>
	IRCON0 <sup>2)</sup>	Interrupt Request Control Register 0	<b>C0H</b> <sup>1)</sup>	00H
	IRCON1	Interrupt Request Control Register 1	D1 <sub>H</sub>	00H
	TCON <sup>2)</sup>	Timer 0/1 Control Register	<b>88H</b> <sup>1)</sup>	00H
	T2CON <sup>2)</sup>	Timer 2 Control Register	<b>C8H</b> <sup>1)</sup>	00H
	S0CON <sup>2)</sup>	Serial Channel 0 Control Register	<b>98H</b> <sup>1)</sup>	00H
CTCON <sup>2)</sup>	Compare Timer Control Register	E1 <sub>H</sub>	0X00 0000B <sup>3)</sup>	
MUL/DIV Unit	ARCON	Arithmetic Control Register	EF <sub>H</sub>	0XXXXXXXXB <sup>3)</sup>
	MD0	Multiplication/Division Register 0	E9 <sub>H</sub>	XX <sub>H</sub> <sup>3)</sup>
	MD1	Multiplication/Division Register 1	EA <sub>H</sub>	XX <sub>H</sub> <sup>3)</sup>
	MD2	Multiplication/Division Register 2	EB <sub>H</sub>	XX <sub>H</sub> <sup>3)</sup>
	MD3	Multiplication/Division Register 3	EC <sub>H</sub>	XX <sub>H</sub> <sup>3)</sup>
	MD4	Multiplication/Division Register 4	ED <sub>H</sub>	XX <sub>H</sub> <sup>3)</sup>
	MD5	Multiplication/Division Register 5	EE <sub>H</sub>	XX <sub>H</sub> <sup>3)</sup>
Timer 0 / Timer 1	TCON <sup>2)</sup>	Timer 0/1 Control Register	<b>88H</b> <sup>1)</sup>	00H
	TH0	Timer 0, High Byte	8C <sub>H</sub>	00H
	TH1	Timer 1, High Byte	8D <sub>H</sub>	00H
	TL0	Timer 0, Low Byte	8A <sub>H</sub>	00H
	TL1	Timer 1, Low Byte	8B <sub>H</sub>	00H
	TMOD	Timer Mode Register	89 <sub>H</sub>	00H

1) Bit-addressable special function registers

2) This special function register is listed repeatedly since some bits of it also belong to other functional blocks.

3) "X" means that the value is undefined and the location is reserved

**Table 2**  
**Special Function Registers - Functional Blocks (cont'd)**

Block	Symbol	Name	Address	Contents after Reset
Compare/ Capture Unit (CCU) Timer 2	CCEN	Compare/Capture Enable Register	C1 <sub>H</sub>	00 <sub>H</sub>
	CC4EN	Compare/Capture 4 Enable Register	C9 <sub>H</sub>	00 <sub>H</sub>
	CCH1	Compare/Capture Register 1, High Byte	C3 <sub>H</sub>	00 <sub>H</sub>
	CCH2	Compare/Capture Register 2, High Byte	C5 <sub>H</sub>	00 <sub>H</sub>
	CCH3	Compare/Capture Register 3, High Byte	C7 <sub>H</sub>	00 <sub>H</sub>
	CCH4	Compare/Capture Register 4, High Byte	CF <sub>H</sub>	00 <sub>H</sub>
	CCL1	Compare/Capture Register 1, Low Byte	C2 <sub>H</sub>	00 <sub>H</sub>
	CCL2	Compare/Capture Register 2, Low Byte	C4 <sub>H</sub>	00 <sub>H</sub>
	CCL3	Compare/Capture Register 3, Low Byte	C6 <sub>H</sub>	00 <sub>H</sub>
	CCL4	Compare/Capture Register 4, Low Byte	CE <sub>H</sub>	00 <sub>H</sub>
	CMEN	Compare Enable Register	F6 <sub>H</sub>	00 <sub>H</sub>
	CMH0	Compare Register 0, High Byte	D3 <sub>H</sub>	00 <sub>H</sub>
	CMH1	Compare Register 1, High Byte	D5 <sub>H</sub>	00 <sub>H</sub>
	CMH2	Compare Register 2, High Byte	D7 <sub>H</sub>	00 <sub>H</sub>
	CMH3	Compare Register 3, High Byte	E3 <sub>H</sub>	00 <sub>H</sub>
	CMH4	Compare Register 4, High Byte	E5 <sub>H</sub>	00 <sub>H</sub>
	CMH5	Compare Register 5, High Byte	E7 <sub>H</sub>	00 <sub>H</sub>
	CMH6	Compare Register 6, High Byte	F3 <sub>H</sub>	00 <sub>H</sub>
	CMH7	Compare Register 7, High Byte	F5 <sub>H</sub>	00 <sub>H</sub>
	CML0	Compare Register 0, Low Byte	D2 <sub>H</sub>	00 <sub>H</sub>
	CML1	Compare Register 1, Low Byte	D4 <sub>H</sub>	00 <sub>H</sub>
	CML2	Compare Register 2, Low Byte	D6 <sub>H</sub>	00 <sub>H</sub>
	CML3	Compare Register 3, Low Byte	E2 <sub>H</sub>	00 <sub>H</sub>
	CML4	Compare Register 4, Low Byte	E4 <sub>H</sub>	00 <sub>H</sub>
	CML5	Compare Register 5, Low Byte	E6 <sub>H</sub>	00 <sub>H</sub>
	CML6	Compare Register 6, Low Byte	F2 <sub>H</sub>	00 <sub>H</sub>
	CML7	Compare Register 7, Low Byte	F4 <sub>H</sub>	00 <sub>H</sub>
	CMSEL	Compare Input Select	F7 <sub>H</sub>	00 <sub>H</sub>
	CRCH	Comp./Rel./Capt. Register High Byte	CB <sub>H</sub>	00 <sub>H</sub>
	CRCL	Comp./Rel./Capt. Register Low Byte	CA <sub>H</sub>	00 <sub>H</sub>
	COMSETL	Compare Set Register Low Byte	A1 <sub>H</sub>	00 <sub>H</sub>
	COMSETH	Compare Set Register, High Byte	A2 <sub>H</sub>	00 <sub>H</sub>
	COMCLRL	Compare Clear Register, Low Byte	A3 <sub>H</sub>	00 <sub>H</sub>
	COMCLRH	Compare Clear Register, High Byte	A4 <sub>H</sub>	00 <sub>H</sub>
	SETMSK	Compare Set Mask Register	A5 <sub>H</sub>	00 <sub>H</sub>
	CLRMSK	Compare Clear Mask Register	A6 <sub>H</sub>	00 <sub>H</sub>
	CTCON <sup>2)</sup>	Compare Timer Control Register	E1 <sub>H</sub>	0X00 0000 <sub>B</sub> <sup>3)</sup>
	CTRELH	Compare Timer Rel. Register, High Byte	DF <sub>H</sub>	00 <sub>H</sub>
	CTRELL	Compare Timer Rel. Register, Low Byte	DE <sub>H</sub>	00 <sub>H</sub>
	TH2	Timer 2, High Byte	CD <sub>H</sub>	00 <sub>H</sub>
	TL2	Timer 2, Low Byte	CC <sub>H</sub>	00 <sub>H</sub>
	T2CON <sup>2)</sup>	Timer 2 Control Register	<b>C8<sub>H</sub></b> <sup>1)</sup>	00 <sub>H</sub>
	IRCON0 <sup>2)</sup>	Interrupt Request Control Register 0	<b>C0<sub>H</sub></b> <sup>1)</sup>	00 <sub>H</sub>

1) Bit-addressable special function registers

2) This special function register is listed repeatedly since some bits of it also belong to other functional blocks.

3) "X" means that the value is undefined and the location is reserved



**Table 2**  
**Special Function Registers - Functional Blocks (cont'd)**

Block	Symbol	Name	Address	Contents after Reset
Ports	P0	Port 0	<b>80H</b> <sup>1)</sup>	FF <sub>H</sub>
	P1	Port 1	<b>90H</b> <sup>1)</sup>	FF <sub>H</sub>
	P2	Port 2	<b>A0H</b> <sup>1)</sup>	FF <sub>H</sub>
	P3	Port 3	<b>B0H</b> <sup>1)</sup>	FF <sub>H</sub>
	P4	Port 4	<b>E8H</b> <sup>1)</sup>	FF <sub>H</sub>
	P5	Port 5	<b>F8H</b> <sup>1)</sup>	FF <sub>H</sub>
	P6	Port 6	FA <sub>H</sub>	FF <sub>H</sub>
	P7	Port 7, Analog/Digital Input	DB <sub>H</sub>	–
	P8	Port 8, Analog/Digital Input, 4-bit	DD <sub>H</sub>	–
XRAM	XPAGE	Page Address Register for Extended On-Chip RAM	91 <sub>H</sub>	00 <sub>H</sub>
	SYSCON <sup>2)</sup>	System/XRAM Control Register	B1 <sub>H</sub>	XXXX XX01 <sub>B</sub> <sup>3)</sup>
Serial Channels	ADCON0 <sup>2)</sup>	A/D Converter Control Register	<b>D8H</b> <sup>1)</sup>	<b>00H</b>
	PCON <sup>2)</sup>	Power Control Register	87 <sub>H</sub>	00 <sub>H</sub>
	S0BUF	Serial Channel 0 Buffer Register	99 <sub>H</sub>	XX <sub>H</sub> <sup>3)</sup>
	S0CON	Serial Channel 0 Control Register	<b>98H</b> <sup>1)</sup>	<b>00H</b>
	S0RELL	Serial Channel 0 Reload Reg., Low Byte	AA <sub>H</sub>	D9 <sub>H</sub>
	S0RELH	Serial Channel 0 Reload Reg., High Byte	BA <sub>H</sub>	XXXX XX11 <sub>B</sub> <sup>3)</sup>
	S1BUF	Serial Channel 1 Buffer Register	9C <sub>H</sub>	XX <sub>H</sub> <sup>3)</sup>
	S1CON	Serial Channel 1 Control Register	9B <sub>H</sub>	0X00 0000 <sub>B</sub> <sup>3)</sup>
	S1RELL	Serial Channel 1 Reload Reg., Low Byte	9D <sub>H</sub>	00 <sub>H</sub>
	S1RELH	Serial Channel 1 Reload Reg., High Byte	BB <sub>H</sub>	XXXX XX11 <sub>B</sub> <sup>3)</sup>
Watchdog	IEN0 <sup>2)</sup>	Interrupt Enable Register 0	<b>A8H</b> <sup>1)</sup>	00 <sub>H</sub>
	IEN1 <sup>2)</sup>	Interrupt Enable Register 1	<b>B8H</b> <sup>1)</sup>	00 <sub>H</sub>
	IPO <sup>2)</sup>	Interrupt Priority Register 0	A9 <sub>H</sub>	00 <sub>H</sub>
	WDTREL	Watchdog Timer Reload Register	86 <sub>H</sub>	00 <sub>H</sub>
Pow. Sav. Modes	PCON <sup>2)</sup>	Power Control Register	87 <sub>H</sub>	00 <sub>H</sub>

1) Bit-addressable special function registers

2) This special function register is listed repeatedly since some bits of it also belong to other functional blocks.

3) "X" means that the value is undefined and the location is reserved.

**Table 3**  
**Contents of the SFRs, SFRs in numeric order of their addresses**

Addr	Register	Content after Reset <sup>1)</sup>	Bit 7	Bit 6	Bit 5	Bit 4	Bit 3	Bit 2	Bit 1	Bit 0
80 <sub>H</sub> <sup>2)</sup>	P0	FF <sub>H</sub>	.7	.6	.5	.4	.3	.2	.1	.0
81 <sub>H</sub>	SP	07 <sub>H</sub>	.7	.6	.5	.4	.3	.2	.1	.0
82 <sub>H</sub>	DPL	00 <sub>H</sub>	.7	.6	.5	.4	.3	.2	.1	.0
83 <sub>H</sub>	DPH	00 <sub>H</sub>	.7	.6	.5	.4	.3	.2	.1	.0
83 <sub>H</sub>	WDTREL	00 <sub>H</sub>	WDT-PSEL	.6	.5	.4	.3	.2	.1	.0
87 <sub>H</sub>	PCON	00 <sub>H</sub>	SMOD	PDS	IDLS	SD	GF1	GF0	PDE	IDLE
88 <sub>H</sub> <sup>2)</sup>	TCON	00 <sub>H</sub>	TF1	TR1	TF0	TR0	IE1	IT1	IE0	IT0
89 <sub>H</sub>	TMOD	00 <sub>H</sub>	GATE	C/ $\bar{T}$	M1	M0	GATE	C/ $\bar{T}$	M1	M0
8A <sub>H</sub>	TL0	00 <sub>H</sub>	.7	.6	.5	.4	.3	.2	.1	.0
8B <sub>H</sub>	TL1	00 <sub>H</sub>	.7	.6	.5	.4	.3	.2	.1	.0
8C <sub>H</sub>	TH0	00 <sub>H</sub>	.7	.6	.5	.4	.3	.2	.1	.0
8D <sub>H</sub>	TH1	00 <sub>H</sub>	.7	.6	.5	.4	.3	.2	.1	.0
90 <sub>H</sub> <sup>2)</sup>	P1	FF <sub>H</sub>	T2	CLK-OUT	T2EX	$\overline{\text{INT2}}$	INT6	INT5	INT4	$\overline{\text{INT3}}$
91 <sub>H</sub>	XPAGE	00 <sub>H</sub>	.7	.6	.5	.4	.3	.2	.1	.0
92 <sub>H</sub>	DPSEL	XXXX-X000 <sub>B</sub>	–	–	–	–	–	.2	.1	.0
98 <sub>H</sub> <sup>2)</sup>	S0CON	00 <sub>H</sub>	SM0	SM1	SM20	REN0	TB80	RB80	TI0	RI0
99 <sub>H</sub>	S0BUF	XX <sub>H</sub>	.7	.6	.5	.4	.3	.2	.1	.0
9A <sub>H</sub>	IEN2	XX00-00X0 <sub>B</sub>	–	–	ECR	ECS	ECT	ECMP	–	ES1
9B <sub>H</sub>	S1CON	0X00-0000 <sub>B</sub>	SM	–	SM21	REN1	TB81	RB81	TI1	RI1
9C <sub>H</sub>	S1BUF	XX <sub>H</sub>	.7	.6	.5	.4	.3	.2	.1	.0
9D <sub>H</sub>	S1RELL	00 <sub>H</sub>	.7	.6	.5	.4	.3	.2	.1	.0
A0 <sub>H</sub> <sup>2)</sup>	P2	FF <sub>H</sub>	.7	.6	.5	.4	.3	.2	.1	.0
A1 <sub>H</sub>	COMSETL	00 <sub>H</sub>	.7	.6	.5	.4	.3	.2	.1	.0
A2 <sub>H</sub>	COMSETH	00 <sub>H</sub>	.7	.6	.5	.4	.3	.2	.1	.0
A3 <sub>H</sub>	COMCLRL	00 <sub>H</sub>	.7	.6	.5	.4	.3	.2	.1	.0

1) X means that the value is undefined and the location is reserved

2) Shaded registers are bit-addressable special function registers

**Table 3**  
**Contents of the SFRs, SFRs in numeric order of their addresses (cont'd)**

Addr	Register	Content after Reset <sup>1)</sup>	Bit 7	Bit 6	Bit 5	Bit 4	Bit 3	Bit 2	Bit 1	Bit 0
A4 <sub>H</sub>	COMCLRH	00 <sub>H</sub>	.7	.6	.5	.4	.3	.2	.1	.0
A5 <sub>H</sub>	SETMSK	00 <sub>H</sub>	.7	.6	.5	.4	.3	.2	.1	.0
A6 <sub>H</sub>	CLRMSK	00 <sub>H</sub>	.7	.6	.5	.4	.3	.2	.1	.0
A8 <sub>H</sub> <sup>2)</sup>	IEN0	00 <sub>H</sub>	EAL	WDT	ET2	ES0	ET1	EX1	ET0	EX0
A9 <sub>H</sub>	IP0	00 <sub>H</sub>	OWDS	WDTS	.5	.4	.3	.2	.1	.0
AA <sub>H</sub>	SORELL	D9 <sub>H</sub>	.7	.6	.5	.4	.3	.2	.1	.0
B0 <sub>H</sub> <sup>2)</sup>	P3	FF <sub>H</sub>	RD	WR	T1	T0	INT1	INT0	TxD0	RxD0
B1 <sub>H</sub>	SYSCON	XXXX-XX01 <sub>B</sub>	–	–	–	–	–	–	XMAP1	XMAP0
B8 <sub>H</sub> <sup>2)</sup>	IEN1	00 <sub>H</sub>	EXEN2	SWDT	EX6	EX5	EX4	EX3	EX2	EADC
B9 <sub>H</sub>	IP1	XX00-0000 <sub>B</sub>	–	–	.5	.4	.3	.2	.1	.0
BA <sub>H</sub>	S0RELH	XXXX-XX11 <sub>B</sub>	–	–	–	–	–	–	.1	.0
BB <sub>H</sub>	S1RELH	XXXX-XX11 <sub>B</sub>	–	–	–	–	–	–	.1	.0
C0 <sub>H</sub> <sup>2)</sup>	IRCON0	00 <sub>H</sub>	EXF2	TF2	IEX6	IEX5	IEX4	IEX3	IEX2	IADC
C1 <sub>H</sub>	CCEN	00 <sub>H</sub>	COCA H3	COCA L3	COCA H2	COCA L2	COCA H1	COCA L1	COCA H0	COCA L0
C2 <sub>H</sub>	CCL1	00 <sub>H</sub>	.7	.6	.5	.4	.3	.2	.1	.0
C3 <sub>H</sub>	CCH1	00 <sub>H</sub>	.7	.6	.5	.4	.3	.2	.1	.0
C4 <sub>H</sub>	CCL2	00 <sub>H</sub>	.7	.6	.5	.4	.3	.2	.1	.0
C5 <sub>H</sub>	CCH2	00 <sub>H</sub>	.7	.6	.5	.4	.3	.2	.1	.0
C6 <sub>H</sub>	CCL3	00 <sub>H</sub>	.7	.6	.5	.4	.3	.2	.1	.0
C7 <sub>H</sub>	CCH3	00 <sub>H</sub>	.7	.6	.5	.4	.3	.2	.1	.0
C8 <sub>H</sub> <sup>2)</sup>	T2CON	00 <sub>H</sub>	T2PS	I3FR	I2FR	T2R1	T2R0	T2CM	T2I1	T2I0
C9 <sub>H</sub>	CC4EN	00 <sub>H</sub>	COCO EN1	COCO N2	COCO N1	COCO N0	COCO EN0	COCA H4	COCA L4	COMO

1) X means that the value is undefined and the location is reserved

2) Shaded registers are bit-addressable special function registers

**Table 3**  
**Contents of the SFRs, SFRs in numeric order of their addresses (cont'd)**

Addr	Register	Content after Reset <sup>1)</sup>	Bit 7	Bit 6	Bit 5	Bit 4	Bit 3	Bit 2	Bit 1	Bit 0
CA <sub>H</sub>	CRCL	00 <sub>H</sub>	.7	.6	.5	.4	.3	.2	.1	.0
CB <sub>H</sub>	CRCH	00 <sub>H</sub>	.7	.6	.5	.4	.3	.2	.1	.0
CC <sub>H</sub>	TL2	00 <sub>H</sub>	.7	.6	.5	.4	.3	.2	.1	.0
CD <sub>H</sub>	TH2	00 <sub>H</sub>	.7	.6	.5	.4	.3	.2	.1	.0
CE <sub>H</sub>	CCL4	00 <sub>H</sub>	.7	.6	.5	.4	.3	.2	.1	.0
CF <sub>H</sub>	CCH4	00 <sub>H</sub>	.7	.6	.5	.4	.3	.2	.1	.0
D0 <sub>H</sub> <sup>2)</sup>	PSW	00 <sub>H</sub>	CY	AC	F0	RS1	RS0	OV	F1	P
D1 <sub>H</sub>	IRCON1	00 <sub>H</sub>	ICMP7	ICMP6	ICMP5	ICMP4	ICMP3	ICMP2	ICMP1	ICMP0
D2 <sub>H</sub>	CML0	00 <sub>H</sub>	.7	.6	.5	.4	.3	.2	.1	.0
D3 <sub>H</sub>	CMH0	00 <sub>H</sub>	.7	.6	.5	.4	.3	.2	.1	.0
D4 <sub>H</sub>	CML1	00 <sub>H</sub>	.7	.6	.5	.4	.3	.2	.1	.0
D5 <sub>H</sub>	CMH1	00 <sub>H</sub>	.7	.6	.5	.4	.3	.2	.1	.0
D6 <sub>H</sub>	CML2	00 <sub>H</sub>	.7	.6	.5	.4	.3	.2	.1	.0
D7 <sub>H</sub>	CMH2	00 <sub>H</sub>	.7	.6	.5	.4	.3	.2	.1	.0
D8 <sub>H</sub> <sup>2)</sup>	ADCON0	00 <sub>H</sub>	BD	CLK	ADEX	BSY	ADM	MX2	MX1	MX0
D9 <sub>H</sub>	ADDATH	00 <sub>H</sub>	.9	.8	.7	.6	.5	.4	.3	.2
DA <sub>H</sub>	ADDATL	00XX-XXXX <sub>B</sub>	.1	.0	–	–	–	–	–	–
DB <sub>H</sub>	P7	–	.7	.6	.5	.4	.3	.2	.1	.0
DC <sub>H</sub>	ADCON1	0XXX-0000 <sub>B</sub>	ADCL	–	–	–	MX3	MX2	MX1	MX0
DD <sub>H</sub>	P8	–	–	–	–	–	.3	.2	.1	.0
DE <sub>H</sub>	CTRELL	00 <sub>H</sub>	.7	.6	.5	.4	.3	.2	.1	.0
DF <sub>H</sub>	CTRELH	00 <sub>H</sub>	.7	.6	.5	.4	.3	.2	.1	.0
E0 <sub>H</sub> <sup>2)</sup>	ACC	00 <sub>H</sub>	.7	.6	.5	.4	.3	.2	.1	.0
E1 <sub>H</sub>	CTCON	0X00.0000 <sub>B</sub>	T2PS1	–	ICR	ICS	CTF	CLK2	CLK1	CLK0
E2 <sub>H</sub>	CML3	00 <sub>H</sub>	.7	.6	.5	.4	.3	.2	.1	.0

1) X means that the value is undefined and the location is reserved

2) Shaded registers are bit-addressable special function registers

**Table 3**  
**Contents of the SFRs, SFRs in numeric order of their addresses (cont'd)**

Addr	Register	Content after Reset <sup>1)</sup>	Bit 7	Bit 6	Bit 5	Bit 4	Bit 3	Bit 2	Bit 1	Bit 0
E3 <sub>H</sub>	CMH3	00 <sub>H</sub>	.7	.6	.5	.4	.3	.2	.1	.0
E4 <sub>H</sub>	CML4	00 <sub>H</sub>	.7	.6	.5	.4	.3	.2	.1	.0
E5 <sub>H</sub>	CMH4	00 <sub>H</sub>	.7	.6	.5	.4	.3	.2	.1	.0
E6 <sub>H</sub>	CML5	00 <sub>H</sub>	.7	.6	.5	.4	.3	.2	.1	.0
E7 <sub>H</sub>	CMH5	00 <sub>H</sub>	.7	.6	.5	.4	.3	.2	.1	.0
E8 <sub>H</sub> <sup>2)</sup>	P4	FF <sub>H</sub>	CM7	CM6	CM5	CM4	CM3	CM2	CM1	CM0
E9 <sub>H</sub>	MD0	XX <sub>H</sub>	.7	.6	.5	.4	.3	.2	.1	.0
EA <sub>H</sub>	MD1	XX <sub>H</sub>	.7	.6	.5	.4	.3	.2	.1	.0
EB <sub>H</sub>	MD2	XX <sub>H</sub>	.7	.6	.5	.4	.3	.2	.1	.0
EC <sub>H</sub>	MD3	XX <sub>H</sub>	.7	.6	.5	.4	.3	.2	.1	.0
ED <sub>H</sub>	MD4	XX <sub>H</sub>	.7	.6	.5	.4	.3	.2	.1	.0
EE <sub>H</sub>	MD5	XX <sub>H</sub>	.7	.6	.5	.4	.3	.2	.1	.0
EF <sub>H</sub>	ARCON	0XXX. XXXX <sub>B</sub>	MDEF	MDOV	SLR	SC.4	SC.3	SC.2	SC.1	SC.0
F0 <sub>H</sub> <sup>2)</sup>	B	00 <sub>H</sub>	.7	.6	.5	.4	.3	.2	.1	.0
F2 <sub>H</sub>	CML6	00 <sub>H</sub>	.7	.6	.5	.4	.3	.2	.1	.0
F3 <sub>H</sub>	CMH6	00 <sub>H</sub>	.7	.6	.5	.4	.3	.2	.1	.0
F4 <sub>H</sub>	CML7	00 <sub>H</sub>	.7	.6	.5	.4	.3	.2	.1	.0
F5 <sub>H</sub>	CMH7	00 <sub>H</sub>	.7	.6	.5	.4	.3	.2	.1	.0
F6 <sub>H</sub>	CMEN	00 <sub>H</sub>	.7	.6	.5	.4	.3	.2	.1	.0
F7 <sub>H</sub>	CMSEL	00 <sub>H</sub>	.7	.6	.5	.4	.3	.2	.1	.0
F8 <sub>H</sub> <sup>2)</sup>	P5	FF <sub>H</sub>	CCM7	CCM6	CCM5	CCM4	CCM3	CCM2	CCM1	CCM0
FA <sub>H</sub>	P6	FF <sub>H</sub>	.7	.6	.5	.4	.3	TxD1	RxD1	ADST

1) X means that the value is undefined and the location is reserved

2) Shaded registers are bit-addressable special function registers

### Digital I/O Ports

The C517A allows for digital I/O on 56 lines grouped into 7 bidirectional 8-bit ports. Each port bit consists of a latch, an output driver and an input buffer. Read and write accesses to the I/O ports P0 through P6 are performed via their corresponding special function registers P0 to P6.

The output drivers of port 0 and 2 and the input buffers of port 0 are also used for accessing external memory. In this application, port 0 outputs the low byte of the external memory address, time-multiplexed with the byte being written or read. Port 2 outputs the high byte of the external memory address when the address is 16 bits wide. Otherwise, the port 2 pins continue emitting the P2 SFR contents.

### Analog Input Ports

Ports 7 (8-bit) and 8 (4-bit) are input ports only and provide two functions. When used as digital inputs, the corresponding SFR P7 and P8 contains the digital value applied to the port 7/8 lines. When used for analog inputs the desired analog channel is selected by a four-bit field in SFR ADCON1. Of course, it makes no sense to output a value to these input-only ports by writing to the SFR P7 or P8. This will have no effect.

If a digital value is to be read, the voltage levels are to be held within the input voltage specifications ( $V_{IL}/V_{IH}$ ). Since P7 and P8 are not bit-addressable, all input lines of P7 and P8 are read at the same time by byte instructions.

Nevertheless, it is possible to use port 7 and 8 simultaneously for analog and digital input. However, care must be taken that all bits of P7 and P8 that have an undetermined value caused by their analog function are masked.

**Timer / Counter 0 and 1**

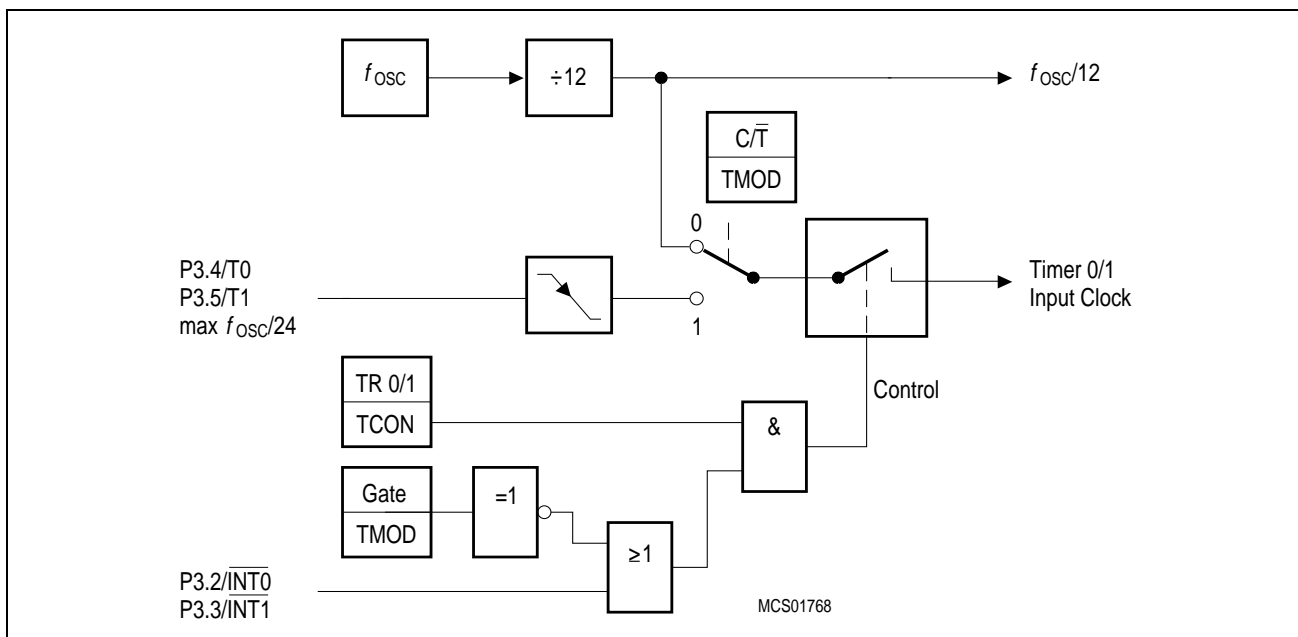
Timer/Counter 0 and 1 can be used in four operating modes as listed in **table 4** :

**Table 4**  
**Timer/Counter 0 and 1 Operating Modes**

Mode	Description	TMOD		Input Clock	
		M1	M0	internal	external (max)
0	8-bit timer/counter with a divide-by-32 prescaler	0	0	$f_{osc}/12 \times 32$	$f_{osc}/24 \times 32$
1	16-bit timer/counter	1	1	$f_{osc}/12$	$f_{osc}/24$
2	8-bit timer/counter with 8-bit autoreload	1	0		
3	Timer/counter 0 used as one 8-bit timer/counter and one 8-bit timer Timer 1 stops	1	1		

In the “timer” function ( $C/\bar{T} = '0'$ ) the register is incremented every machine cycle. Therefore the count rate is  $f_{osc}/12$ .

In the “counter” function the register is incremented in response to a 1-to-0 transition at its corresponding external input pin (P3.4/T0, P3.5/T1). Since it takes two machine cycles to detect a falling edge the max. count rate is  $f_{osc}/24$ . External inputs  $\overline{INT0}$  and  $\overline{INT1}$  (P3.2, P3.3) can be programmed to function as a gate to facilitate pulse width measurements. **Figure 10** illustrates the input clock logic.

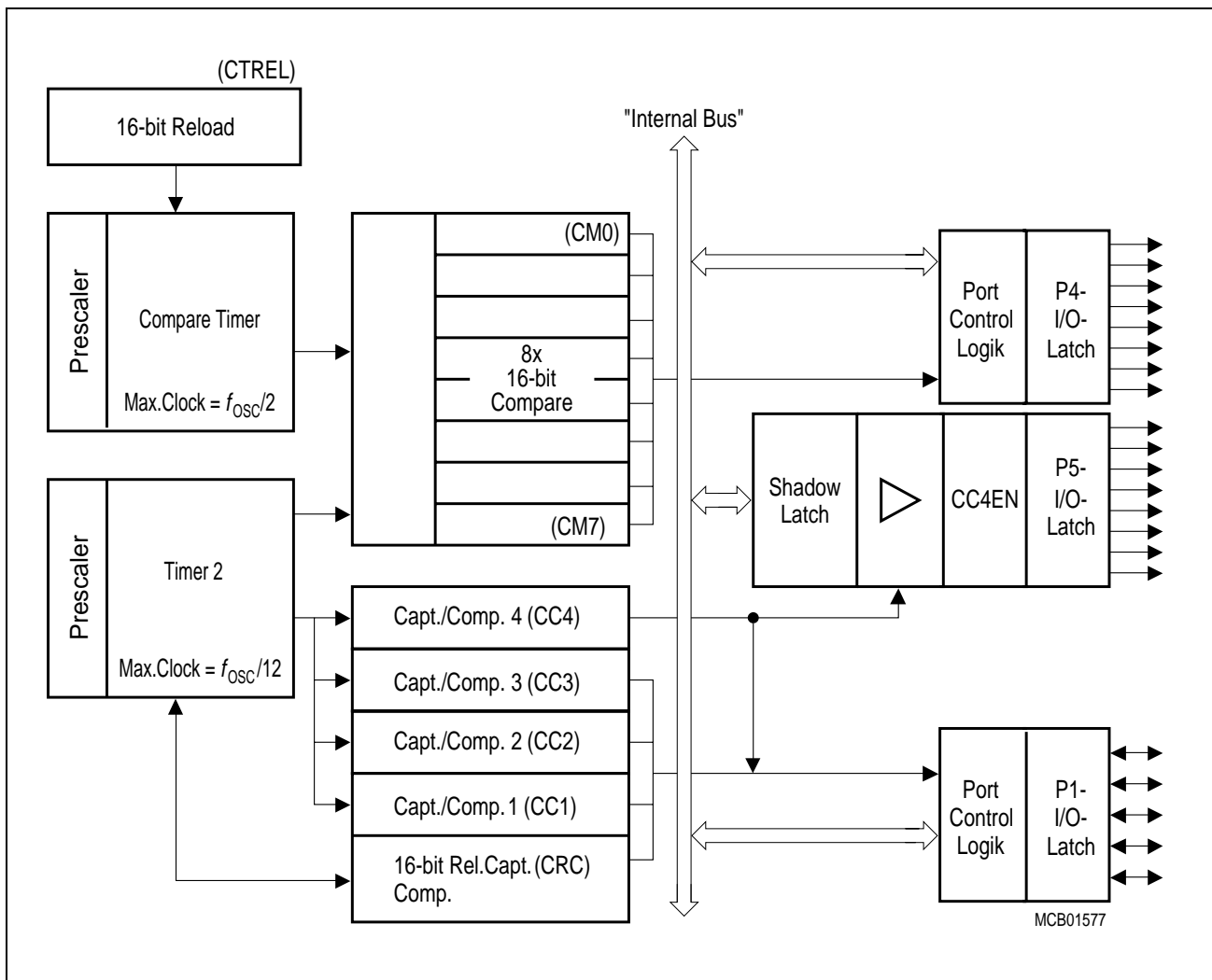


**Figure 10**  
**Timer/Counter 0 and 1 Input Clock Logic**

**Cmpare / Capture Unit (CCU)**

The compare/capture unit is one of the C517A's most powerful peripheral units for use in all kinds of digital signal generation and event capturing like pulse generation, pulse width modulation, pulse width measuring etc. The CCU consists of two 16-bit timer/counters with automatic reload feature and an array of 13 compare or compare/capture registers. A set of six control registers is used for flexible adapting of the CCU to a wide variety of user's applications.

The block diagram in **figure 11** shows the general configuration of the CCU. All CC1 to CC4 registers and the CRC register are exclusively assigned to timer 2. Each of the eight compare registers CM0 through CM7 can either be assigned to timer 2 or to the faster compare timer, e.g. to provide up to 8 PWM output channels. The assignment of the CMx registers - which can be done individually for every single register - is combined with an automatic selection of one of the two possible compare modes.



**Figure 11**  
**Timer 2 Block Diagram**



The main functional blocks of the CCU are :

- Timer 2 with  $f_{osc}/12$  input clock, 2-bit prescaler, 16-bit reload, counter/gated timer mode and overflow interrupt request.
- Compare timer with  $f_{osc}/2$  input clock, 3-bit prescaler, 16-bit reload and overflow interrupt request.
- Compare/(reload)/capture register array consisting of four different kinds of registers:
  - one 16-bit compare/reload/capture register,
  - three 16-bit compare/capture registers,
  - one 16-bit compare/capture register with additional "concurrent compare" feature,
  - eight 16-bit compare registers with timer-overflow controlled loading.

**Table 5** shows the possible configurations of the CCU and the corresponding compare modes which can be selected. The following sections describe the function of these configurations.

**Table 5**  
**CCU Configurations**

Assigned Timer	Compare Register	Compare Output at	Possible Modes
Timer 2	CRCH/CRCL	P1.0/ $\overline{\text{INT3}}$ /CC0	Compare mode 0, 1 + Reload
	CCH1/CCL1	P1.1/INT4/CC1	Compare mode 0, 1 / capture
	CCH2/CCL2	P1.2/INT5/CC2	Compare mode 0, 1 / capture
	CCH3/CCL3	P1.3/INT6/CC3	Compare mode 0, 1 / capture
	CCH4/CCL4	P1.4/ $\overline{\text{INT2}}$ /CC4	Compare mode 0, 1 / capture
	CCH4/CCL4	P1.4/ $\overline{\text{INT2}}$ /CC4 P5.0/CCM0 to P5.7/CCM7	Compare mode 1 "Concurrent compare"
	CMH0/CML0 to CMH7/CML7	P4.0/CM0 to P4.7/CM7	Compare mode 0
	COMSET COMCLR	P5.0/CCM0 to P5.7/CCM7	Compare mode 2
Compare Timer	CMH0/CML0 to CMH7/CML7	P4.0/CM0 to P4.7/CM7	Compare mode 1

**Timer 2 Operation**

Timer Mode : In timer function, the count rate is derived from the oscillator frequency. A prescaler offers the possibility of selecting a count rate of 1/12 or 1/24 of the oscillator frequency.

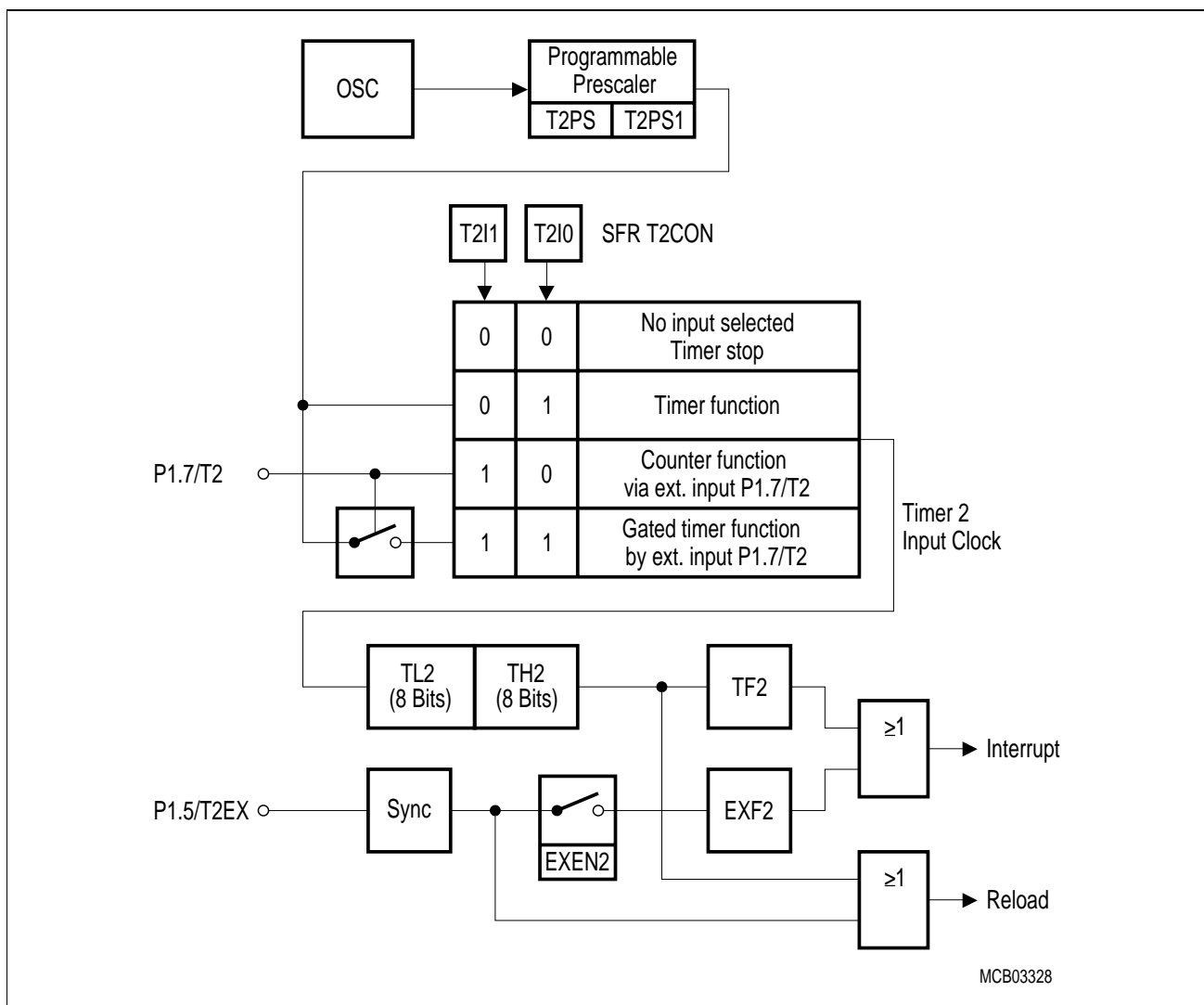
Gated Timer Mode : In gated timer function, the external input pin P1.7/T2 operates as a gate to the input of timer 2. If T2 is high, the internal clock input is gated to the timer. T2 = 0 stops the counting procedure. The external gate signal is sampled once every machine cycle.

Event Counter Mode : In the event counter function, the timer 2 is incremented in response to a 1-to-0 transition at its corresponding external input pin P1.7/T2. In this function, the external input is sampled every machine cycle. The maximum count rate is 1/24 of the oscillator frequency.

Reload of Timer 2 : Two reload modes are selectable:

In mode 0, when timer 2 rolls over from all 1's to all 0's, it not only sets TF2 but also causes the timer 2 registers to be loaded with the 16-bit value in the CRC register, which is preset by software.

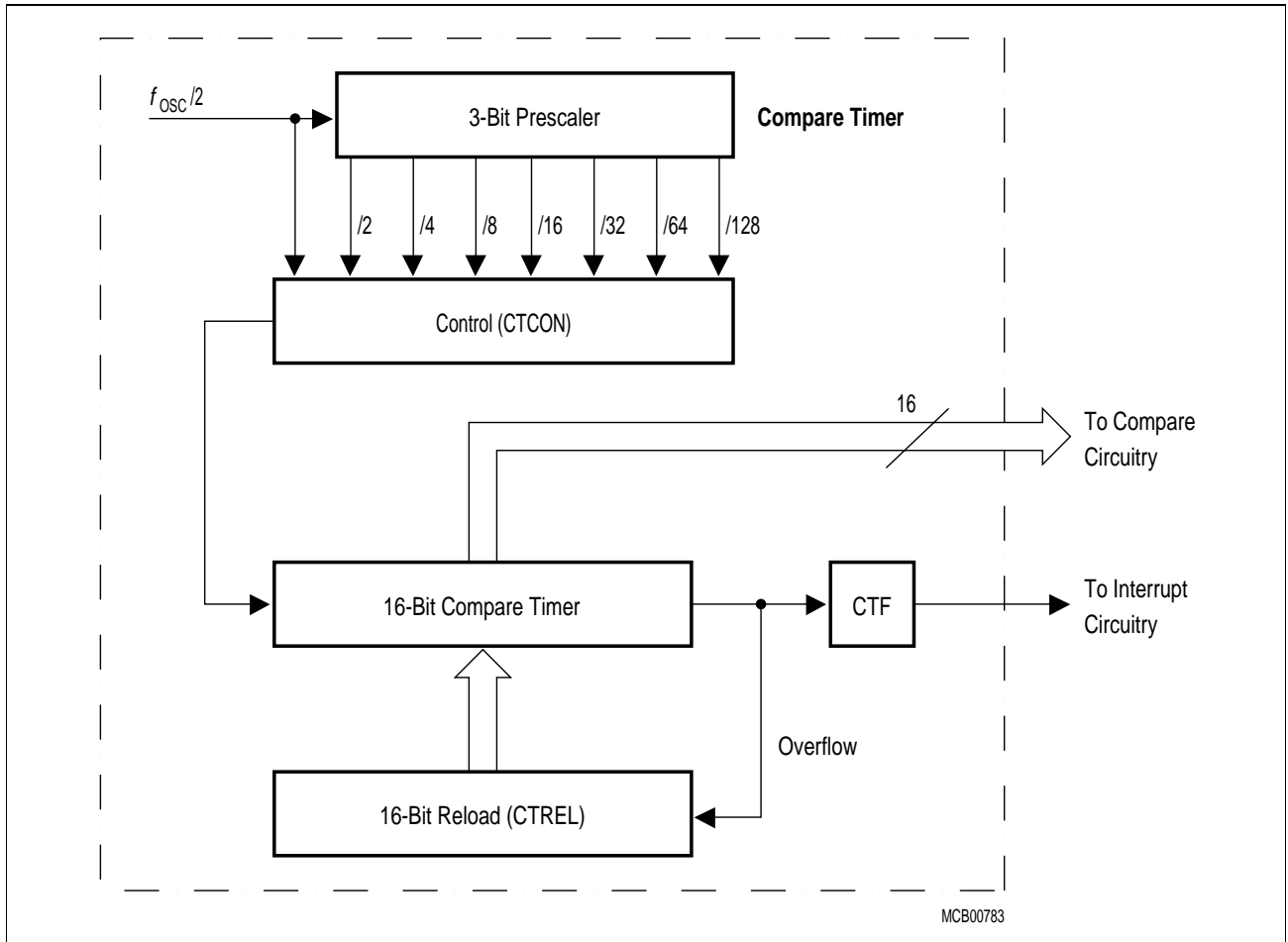
In mode 1, a 16-bit reload from the CRC register is caused by a negative transition at the corresponding input pin P1.5/T2EX.



**Figure 12**  
**Block Diagram of Timer 2**

**Compare Timer Operation**

The compare timer receives its input clock from a programmable prescaler which provides input frequencies, ranging from  $f_{osc}/2$  up to  $f_{osc}/256$ . The compare timer is, once started, a free-running 16-bit timer, which on overflow is automatically reloaded by the contents of a 16-bit reload register. The compare timer has - as any other timer in the C517A - their own interrupt request flags CTF. These flags are set when the timer count rolls over from all ones to the reload value. **Figure 13** shows the block diagram of compare timer and compare timer 1.



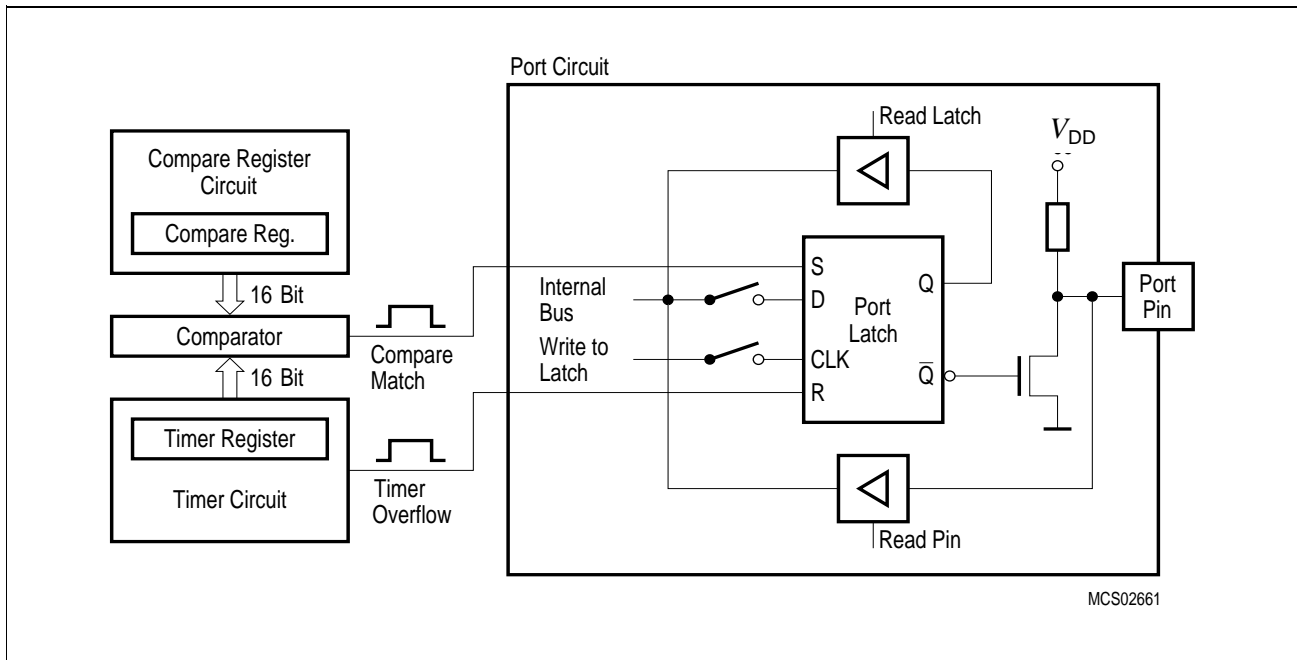
**Figure 13**  
**Compare Timer Block Diagram**

**Compare Modes**

The compare function of a timer/register combination operates as follows : the 16-bit value stored in a compare or compare/capture register is compared with the contents of the timer register; if the count value in the timer register matches the stored value, an appropriate output signal is generated at a corresponding port pin and an interrupt can be generated.

Compare Mode 0

In compare mode 0, upon matching the timer and compare register contents, the output signal changes from low to high. It goes back to a low level on timer overflow. As long as compare mode 0 is enabled, the appropriate output pin is controlled by the timer circuit only and writing to the port will have no effect. **Figure 14** shows a functional diagram of a port circuit when used in compare mode 0. The port latch is directly controlled by the timer overflow and compare match signals. The input line from the internal bus and the write-to-latch line of the port latch are disconnected when compare mode 0 is enabled.

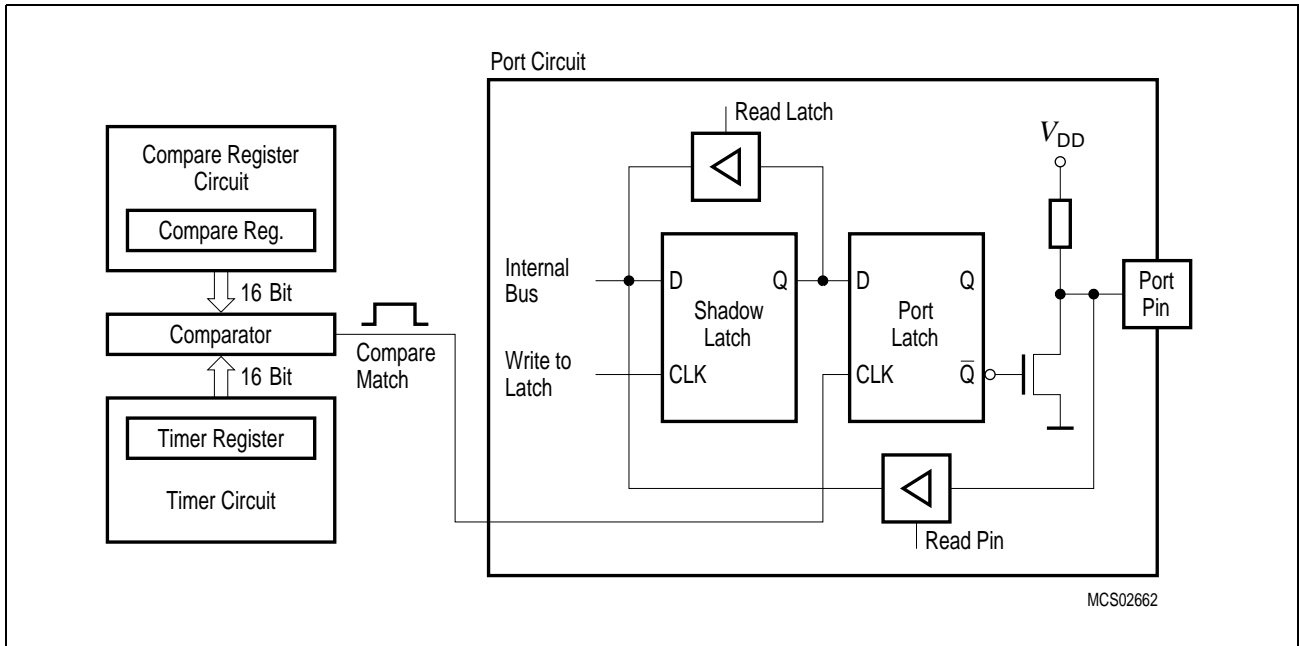


**Figure 14**  
**Port Latch in Compare Mode 0**

Compare Mode 1

If compare mode 1 is enabled and the software writes to the appropriate output latch at the port, the new value will not appear at the output pin until the next compare match occurs. Thus, it can be chosen whether the output signal has to make a new transition (1-to-0 or 0-to-1, depending on the actual pin-level) or should keep its old value at the time when the timer value matches the stored compare value.

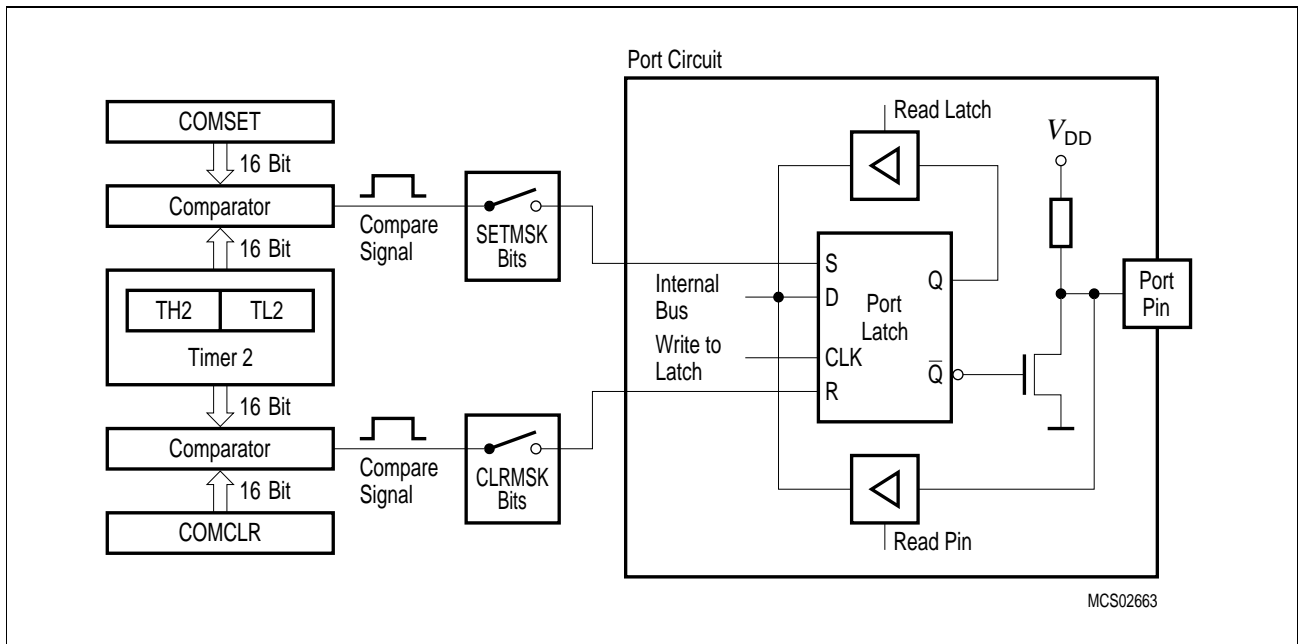
In compare mode 1 (see **figure 15**) the port circuit consists of two separate latches. One latch (which acts as a "shadow latch") can be written under software control, but its value will only be transferred to the port latch (and thus to the port pin) when a compare match occurs.



**Figure 15**  
**Compare Function in Compare Mode 1**

Compare Mode 2

In the compare mode 2 the port 5 pins are under control of compare/capture register CC4, but under control of the compare registers COMSET and COMCLR. When a compare match occurs with register COMSET, a high level appears at the pins of port 5 when the corresponding bits in the mask register SETMSK are set. When a compare match occurs with register COMCLR, a low level appears at the pins of port 5 when the corresponding bits in the mask register CLRMSK are set.



**Figure 16**  
**Compare Function of Compare Mode 2**

**Multiplication / Division Unit (MDU)**

This on-chip arithmetic unit of the C517A provides fast 32-bit division, 16-bit multiplication as well as shift and normalize features. All operations are unsigned integer operations. **Table 6** describes the five general operations the MDU is able to perform.

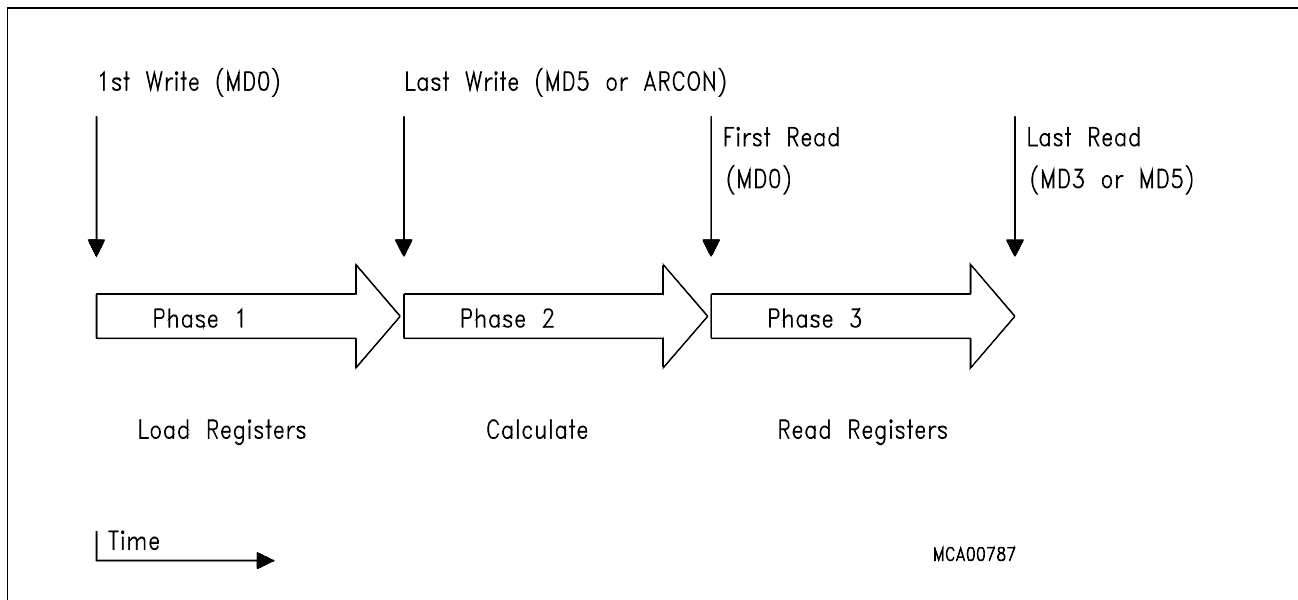
**Table 6**  
**MDU Operation Characteristics**

Operation	Result	Remainder	Execution Time
32bit/16bit	32bit	16bit	6 $t_{CY}^{1)}$
16bit/16bit	16bit	16bit	4 $t_{CY}^{1)}$
16bit x 16bit	32bit	–	4 $t_{CY}^{1)}$
32-bit normalize	–	–	6 $t_{CY}^{2)}$
32-bit shift L/R	–	–	6 $t_{CY}^{2)}$

1) 1  $t_{CY}$  = 12  $t_{CLCL}$  = 1 machine cycle = 500 ns at 24 MHz oscillator frequency

2) The maximal shift speed is 6 shifts per machine cycle

The MDU consists of seven special function registers (MD0-MD5, ARCON) which are used as operand, result, and control registers. The three operation phases are shown in **figure 17**.



**Figure 17**  
**Operating Phases of the MDU**

For starting an operation, registers MD0 to MD5 and ARCON must be written to in a certain sequence according **table 7** and **8**. The order the registers are accessed determines the type of the operation. A shift operation is started by a final write operation to SFR ARCON.

**Table 7**  
**Programming the MDU for Multiplication and Division**

Operation	32Bit/16Bit	16Bit/16Bit	16Bit x 16Bit
First Write	MD0 D'endL	MD0 D'endL	MD0 M'andL
	MD1 D'end	MD1 D'endH	MD4 M'orL
	MD2 D'end		
	MD3 D'endH	MD4 D'orL	MD1 M'andH
	MD4 D'orL		
Last Write	MD5 D'orH	MD5 D'orH	MD5 M'orH
First Read	MD0 QuoL	MD0 QuoL	MD0 PrL
	MD1 Quo	MD1 QuoH	MD1
	MD2 Quo		
	MD3 QuoH	MD4 RemL	MD2
	MD4 RemL		
Last Read	MD5 RemH	MD5 RemH	MD3 PrH

**Abbreviations :**

- D'end : Dividend, 1st operand of division
- D'or : Divisor, 2nd operand of division
- M'and : Multiplicand, 1st operand of multiplication
- M'or : Multiplier, 2nd operand of multiplication
- Pr : Product, result of multiplication
- Rem : Remainder
- Quo : Quotient, result of division
- ...L : means, that this byte is the least significant of the 16-bit or 32-bit operand
- ...H : means, that this byte is the most significant of the 16-bit or 32-bit operand

**Table 8**  
**Programming the MDU for a Shift or Normalize Operation**

Operation	Normalize, Shift Left, Shift Right
First write	MD0 least significant byte
	MD1 .
	MD2 .
	MD3 most significant byte
	ARCON start of conversion
Last write	
First read	MD0 least significant byte
	MD1 .
	MD2 .
Last read	MD3 most significant byte

## Serial Interfaces 0 and 1

The C517A has two serial interfaces which are functionally nearly identical concerning the asynchronous modes of operation. The two channels are full-duplex, meaning they can transmit and receive simultaneously. The serial channel 0 is completely compatible with the serial channel of the C501 (one synchronous mode, three asynchronous modes). Serial channel 1 has the same functionality in its asynchronous modes, but the synchronous mode and the fixed baud rate UART mode is missing.

The operating modes of the serial interfaces is illustrated in **table 9**. The possible baudrates can be calculated using the formulas given in **table 10**.

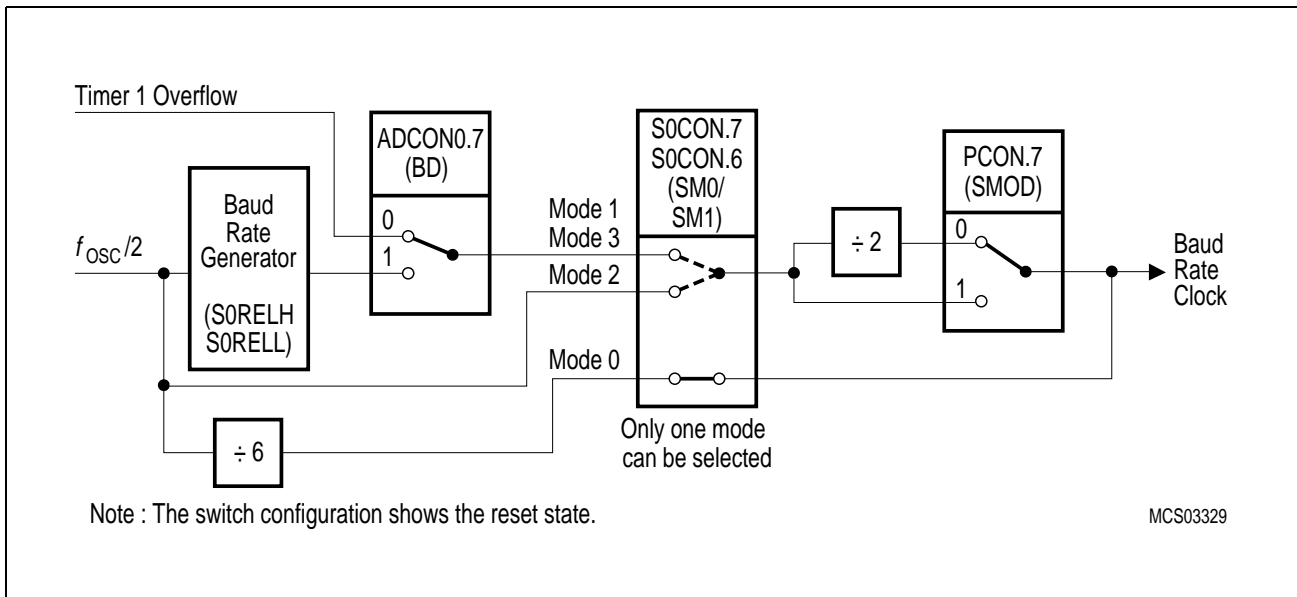
**Table 9**  
**Operating Modes of Serial Interface 0 and 1**

Serial Interface	Mode	S0CON		S1CON	Description
		SM0	SM1	SM	
0	0	0	0	–	Shift register mode Serial data enters and exits through RxD0; TxD0 outputs the shift clock; 8-bit are transmitted/received (LSB first); fixed baud rate
	1	0	1	–	8-bit UART, variable baud rate 10 bits are transmitted (through TxD0) or received (at RxD0)
	2	1	0	–	9-bit UART, fixed baud rate 11 bits are transmitted (through TxD0) or received (at RxD0)
	3	1	1	–	9-bit UART, variable baud rate Like mode 2
1	A	–	–	0	9-bit UART; variable baud rate 11 bits are transmitted (through TxD1) or received (at RxD1)
	B	–	–	1	8-bit UART; variable baud rate 10 bits are transmitted (through TxD1) or received (at RxD1)

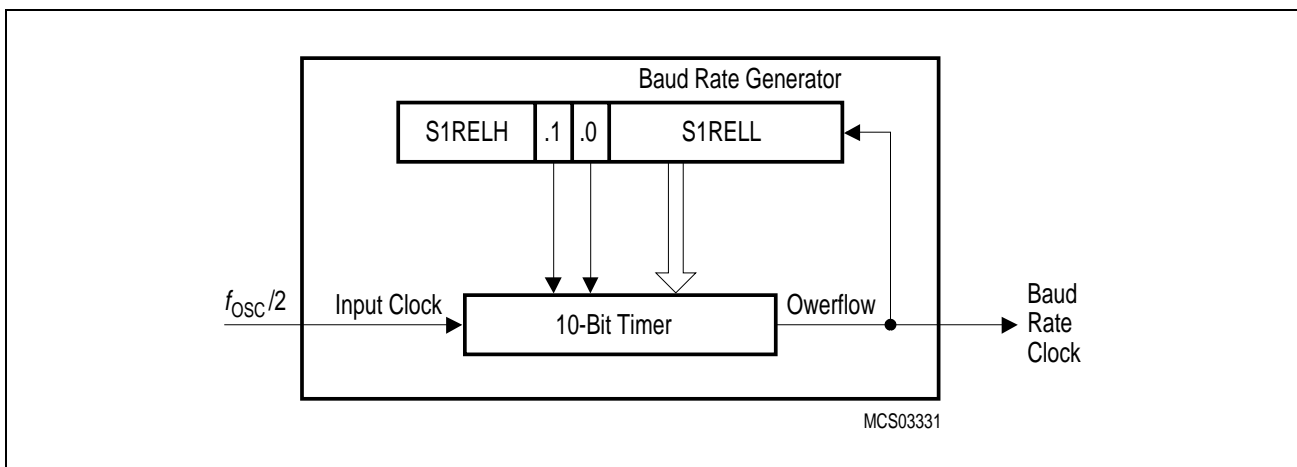


For clarification some terms regarding the difference between "baud rate clock" and "baud rate" should be mentioned. In the asynchronous modes the serial interfaces require a clock rate which is 16 times the baud rate for internal synchronization. Therefore, the baud rate generators/timers have to provide a "baud rate clock" (output signal in **figure 18** and **figure 19**) to the serial interface which - there divided by 16 - results in the actual "baud rate". Further, the abbreviation  $f_{OSC}$  refers to the oscillator frequency (crystal or external clock operation).

The variable baud rates for modes 1 and 3 of the serial interface 0 can be derived from either timer 1 or a dedicated baud rate generator (see **figure 18**). The variable baud rates for modes A and B of the serial interface 1 are derived from a dedicated baud rate generator as shown in **figure 19**.



**Figure 18**  
**Serial Interface 0 : Baud Rate Generation Configuration**



**Figure 19**  
**Serial Interface 1 : Baud Rate Generator Configuration**

The baud rate generator block in **figure 18** has the same structure (10-bit auto-reload timer) as the baud rate generator block which is shown in detail in **figure 19**.

**Table 10** below lists the values/formulas for the baud rate calculation of serial interface 0 and 1 with its dependencies of the control bits BD and SMOD.

**Table 10**  
**Serial Interfaces - Baud Rate Dependencies**

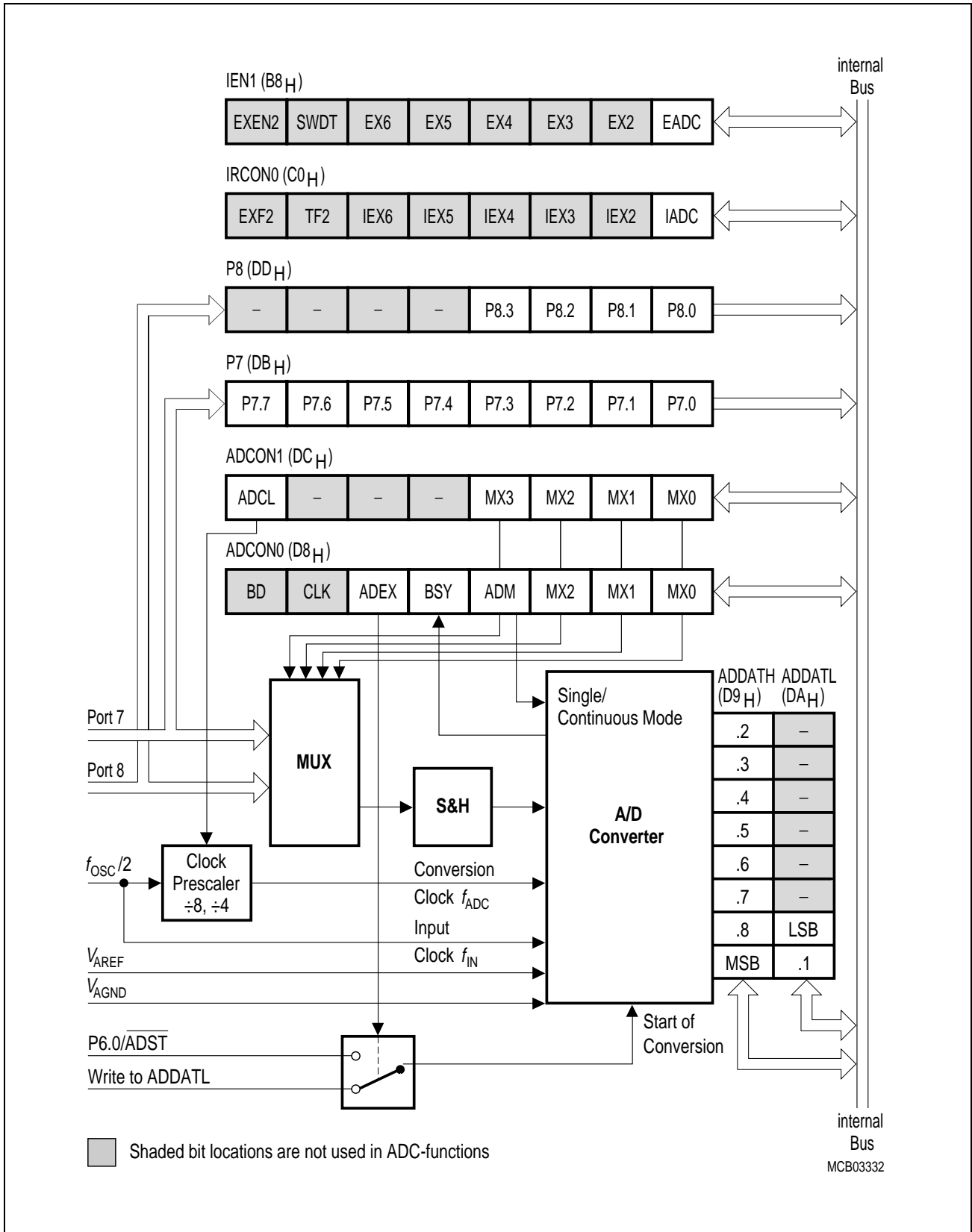
Serial Interface Operating Modes	Active Control Bits		Baud Rates
	SMOD	BD	
Mode 0 (Shift Register)	–	–	Fixed baud rate clock $f_{osc}/12$
Mode 1 (8-bit UART) Mode 3 (9-bit UART)	X	0	Timer 1 overflow is used for baud rate generation; SMOD controls a divide-by-2 option. Baud rate = $2^{SMOD} \times \text{timer 1 overflow rate} / 32$
		1	Baud rate generator is used for baud rate generation; SMOD controls a divide-by-2 option Baud rate = $2^{SMOD} \times \text{oscillator frequency} / 64 \times (\text{baud rate gen. overflow rate})$
Mode 2 (9-bit UART)	X	–	Fixed baud rate clock $f_{osc}/32$ (SMOD=1) or $f_{osc}/64$ (SMOD=0)
Mode A (9-bit UART) Mode B (8-bit UART)	–	–	Baud rate generator is used for baud rate generation; SMOD controls a divide-by-2 option Baud rate = $\text{oscillator frequency} / 32 \times (\text{baud rate gen. overflow rate})$

### 10-Bit A/D Converter

The C517A provides an A/D converter with the following features:

- 12 multiplexed input channels (port 7, 8), which can also be used as digital inputs
- 10-bit resolution
- Single or continuous conversion mode
- Internal or external start-of-conversion trigger capability
- Interrupt request generation after each conversion
- Using successive approximation conversion technique via a capacitor array
- Built-in hidden calibration of offset and linearity errors

The A/D converter operates with a successive approximation technique and uses self calibration mechanisms for reduction and compensation of offset and linearity errors. The externally applied reference voltage range has to be held on a fixed value within the specifications. The main functional blocks of the A/D converter are shown in **figure 20**.

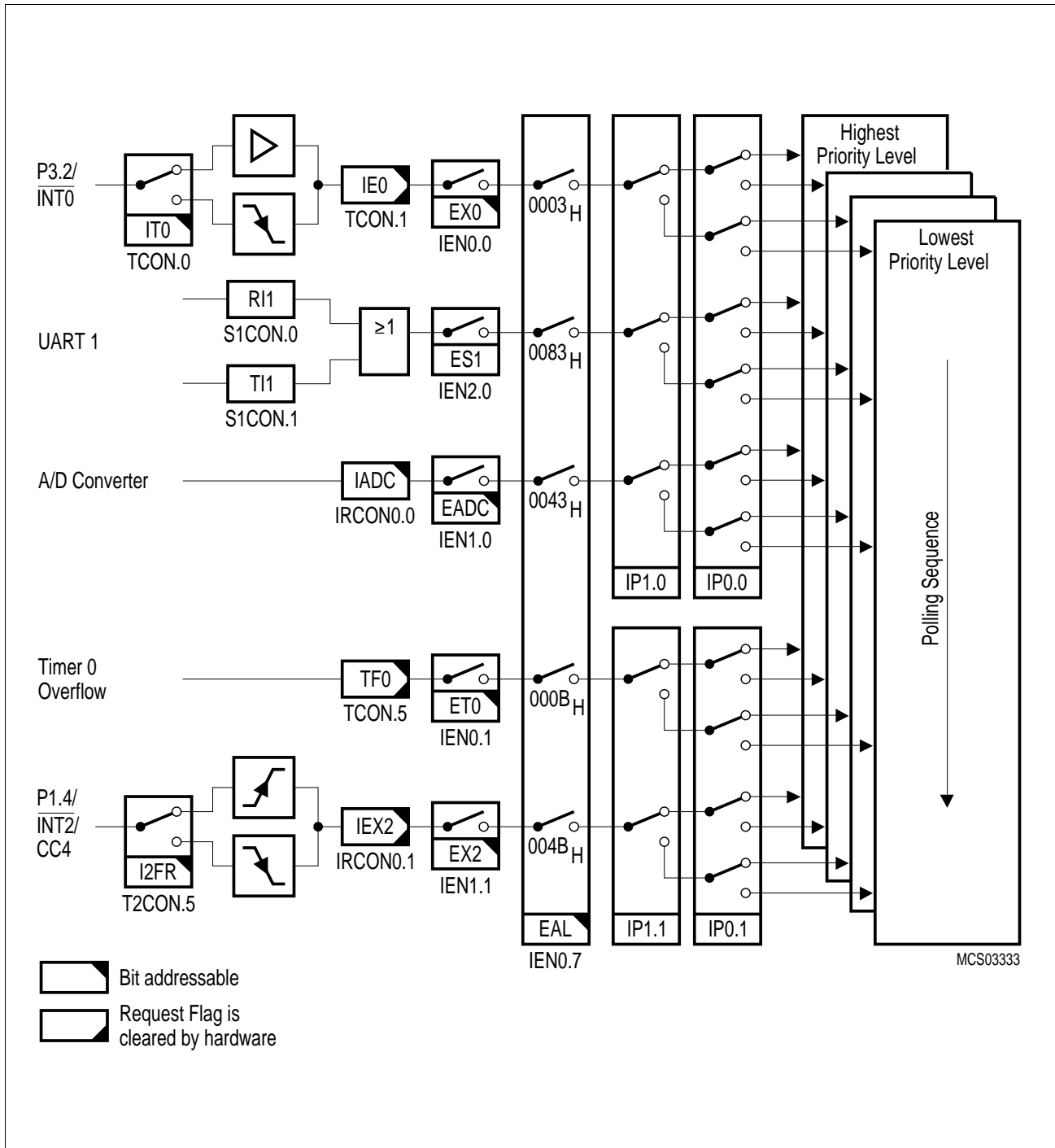


**Figure 20**  
**A/D Converter Block Diagram**

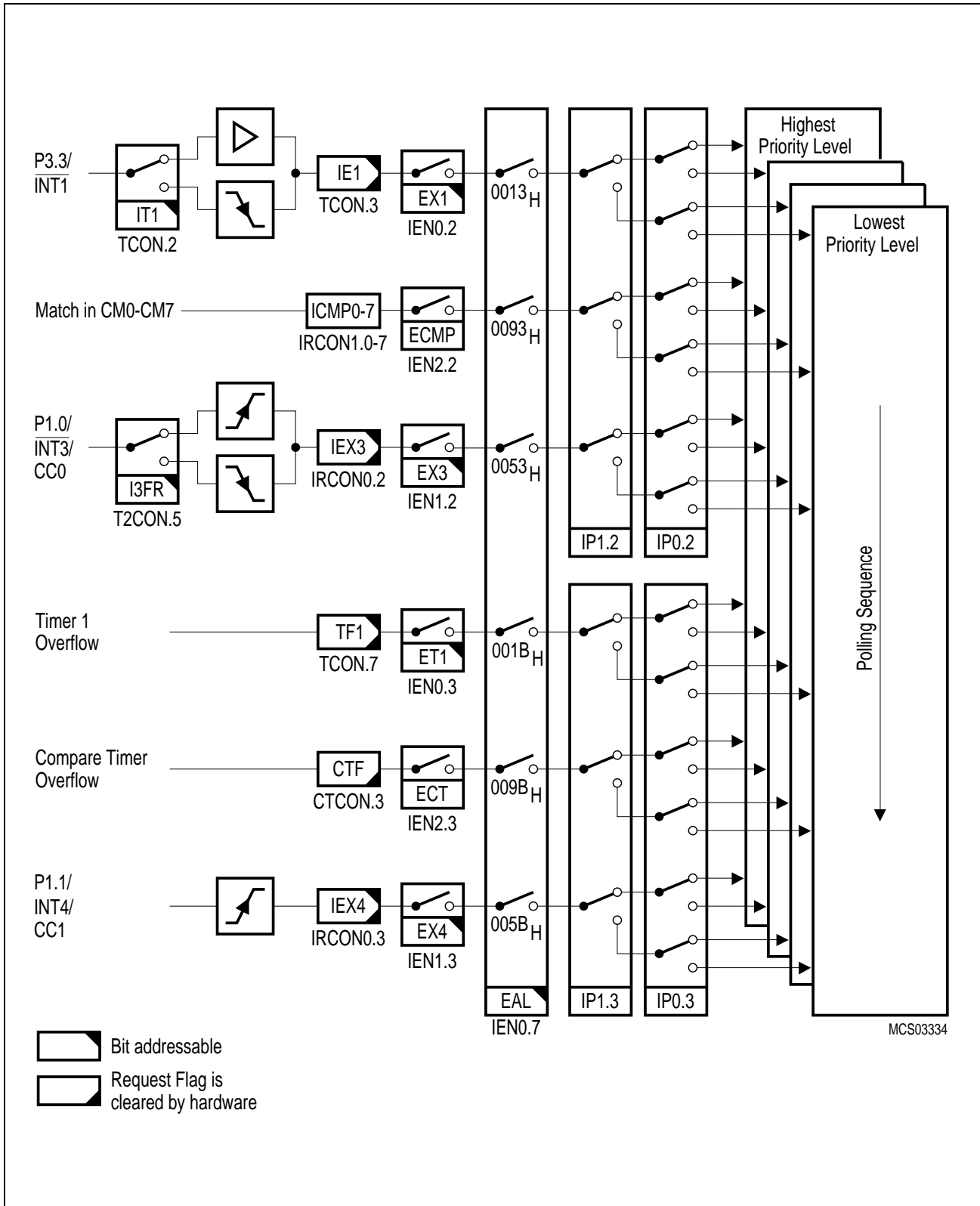
## Interrupt System

The C517A provides 17 interrupt sources with four priority levels. Ten interrupts can be generated by the on-chip peripherals (timer 0, timer 1, timer 2, compare timer, compare match/set/clear, A/D converter, and serial interface 0 and 1) and seven interrupts may be triggered externally (P3.2/ $\overline{\text{INT0}}$ , P3.3/ $\overline{\text{INT1}}$ , P1.4/ $\overline{\text{INT2}}$ , P1.0/ $\overline{\text{INT3}}$ , P1.1/ $\text{INT4}$ , P1.2/ $\text{INT5}$ , P1.3/ $\text{INT6}$ ).

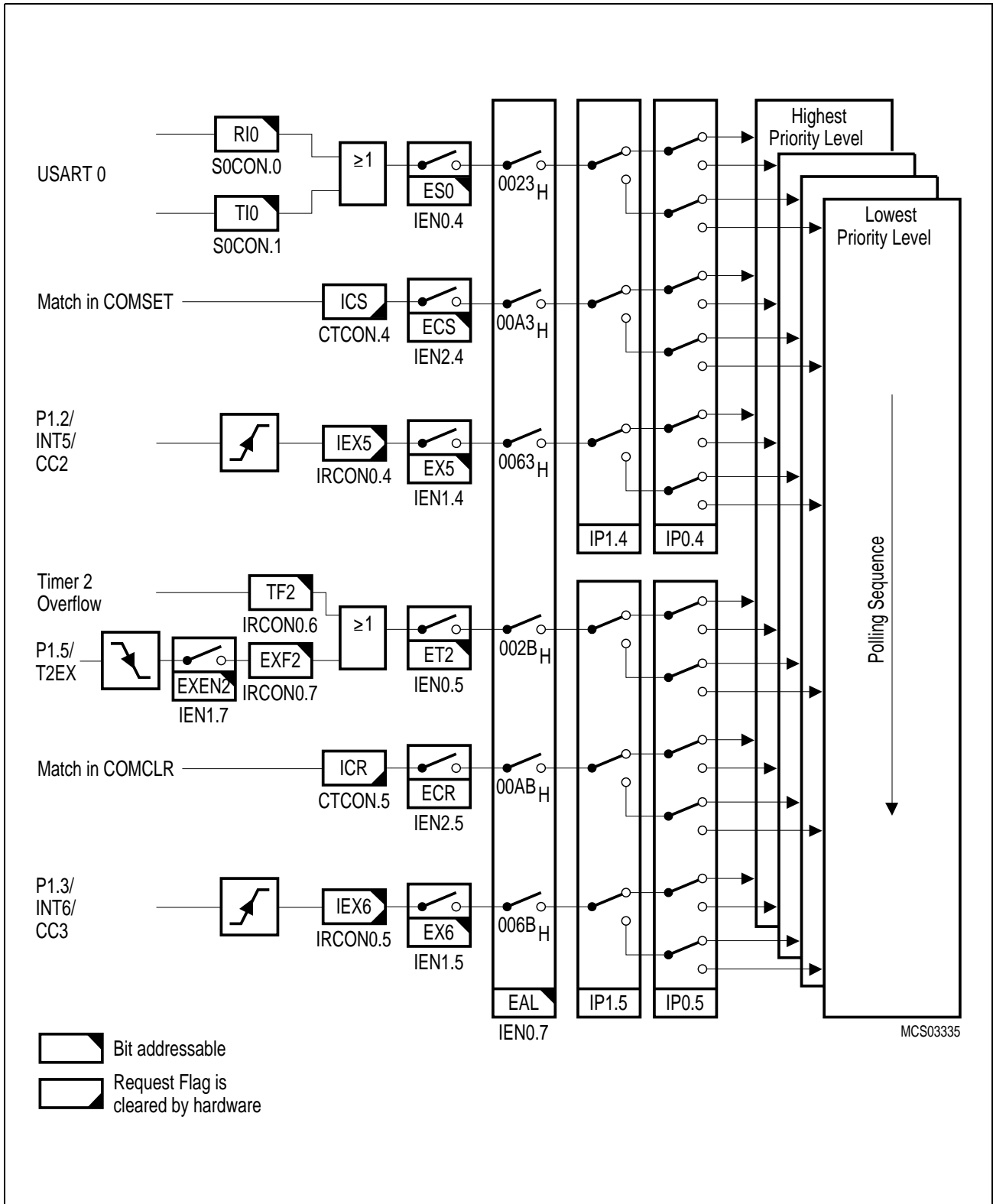
This chapter shows the interrupt structure, the interrupt vectors and the interrupt related special function registers. **Figure 21** to **23** give a general overview of the interrupt sources and illustrate the request and the control flags which are described in the next sections.



**Figure 21**  
Interrupt Structure, Overview (Part 1)



**Figure 22**  
**Interrupt Structure, Overview (Part 2)**



**Figure 23**  
**Interrupt Structure, Overview (Part 3)**



**Table 11**  
**Interrupt Source and Vectors**

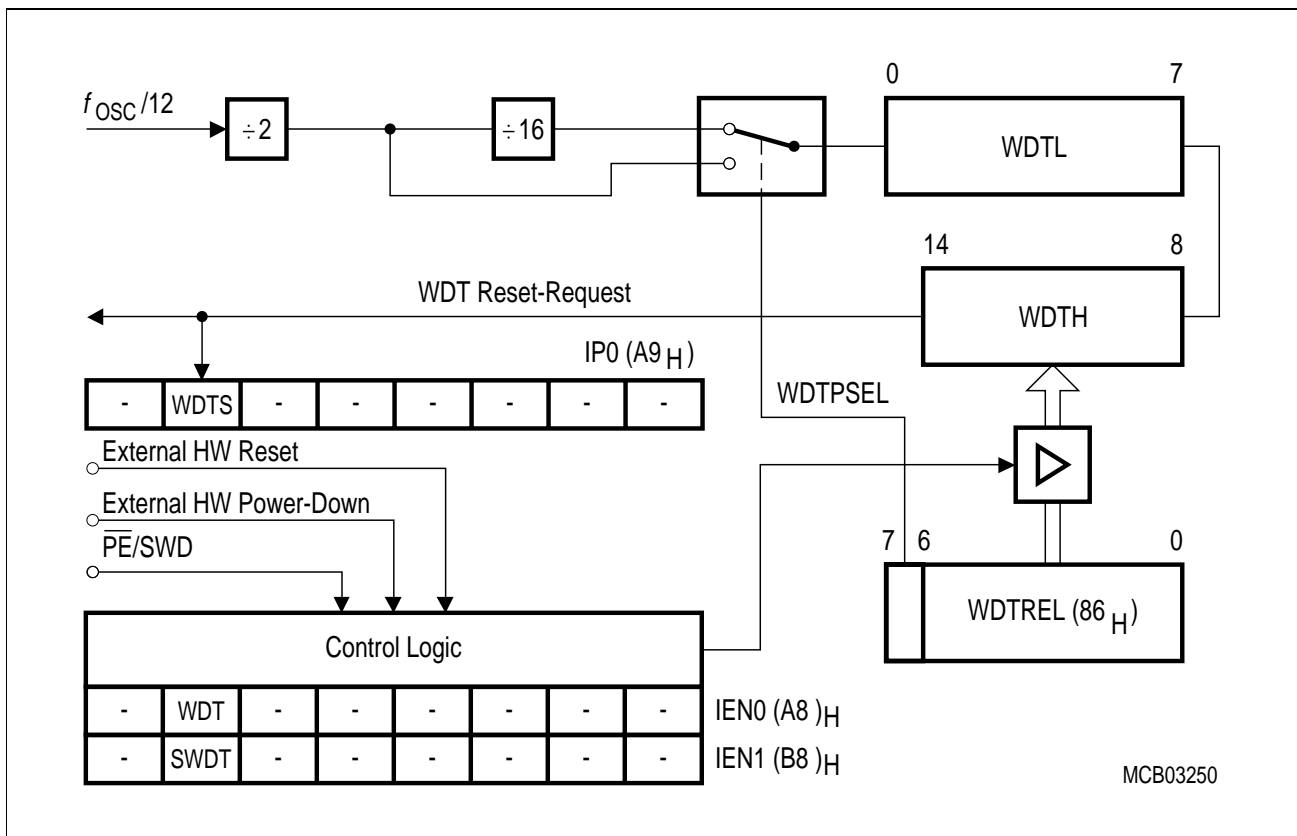
Interrupt Source	Interrupt Vector Address	Interrupt Request Flags
External Interrupt 0	0003 <sub>H</sub>	IE0
Timer 0 Overflow	000B <sub>H</sub>	TF0
External Interrupt 1	0013 <sub>H</sub>	IE1
Timer 1 Overflow	001B <sub>H</sub>	TF1
Serial Channel 0	0023 <sub>H</sub>	RI0 / TI0
Timer 2 Overflow / Ext. Reload	002B <sub>H</sub>	TF2 / EXF2
A/D Converter	0043 <sub>H</sub>	IADC
External Interrupt 2	004B <sub>H</sub>	IEX2
External Interrupt 3	0053 <sub>H</sub>	IEX3
External Interrupt 4	005B <sub>H</sub>	IEX4
External Interrupt 5	0063 <sub>H</sub>	IEX5
External Interrupt 6	006B <sub>H</sub>	IEX6
Serial Channel 1	0083 <sub>H</sub>	RI1 / TI1
Compare Match Interupt of Compare Registers CM0-CM7 assigned to Timer 2	0093 <sub>H</sub>	ICMP0 - ICMP7
Compare Timer Overflow	009B <sub>H</sub>	CTF
Compare Match Interupt of Compare Register COMSET	00A3 <sub>H</sub>	ICS
Compare Match Interupt of Compare Register COMCLR	00AB <sub>H</sub>	ICR

**Fail Save Mechanisms**

The C517A offers enhanced fail safe mechanisms, which allow an automatic recovery from software upset or hardware failure :

- a programmable watchdog timer (WDT), with variable time-out period from 512  $\mu$ s up to approx. 1.1 s at 12 MHz. (256  $\mu$ s up to approx. 0.65 s at 24 MHz)
- an oscillator watchdog (OWD) which monitors the on-chip oscillator and forces the microcontroller into reset state in case the on-chip oscillator fails; it also provides the clock for a fast internal reset after power-on.

The watchdog timer in the C517A is a 15-bit timer, which is incremented by a count rate of  $f_{osc}/24$  up to  $f_{osc}/384$ . The system clock of the C517A is divided by two prescalers, a divide-by-two and a divide-by-16 prescaler. For programming of the watchdog timer overflow rate, the upper 7 bit of the watchdog timer can be written. **Figure 24** shows the block diagram of the watchdog timer unit.



**Figure 24**  
**Block Diagram of the Watchdog Timer**

The watchdog timer can be started by software (bit SWDT) or by hardware through pin  $\overline{PE}/SWD$ , but it cannot be stopped during active mode of the C517A. If the software fails to refresh the running watchdog timer an internal reset will be initiated on watchdog timer overflow. For refreshing of the watchdog timer the content of the SFR WDTRE is transferred to the upper 7-bit of the watchdog timer. The refresh sequence consists of two consecutive instructions which set the bits WDT and SWDT each. The reset cause (external reset or reset caused by the watchdog) can be examined by software (flag WDTS). It must be noted, however, that the watchdog timer is halted during the idle mode and power down mode of the processor.

**Oscillator Watchdog**

The oscillator watchdog unit serves for four functions:

– **Monitoring of the on-chip oscillator’s function**

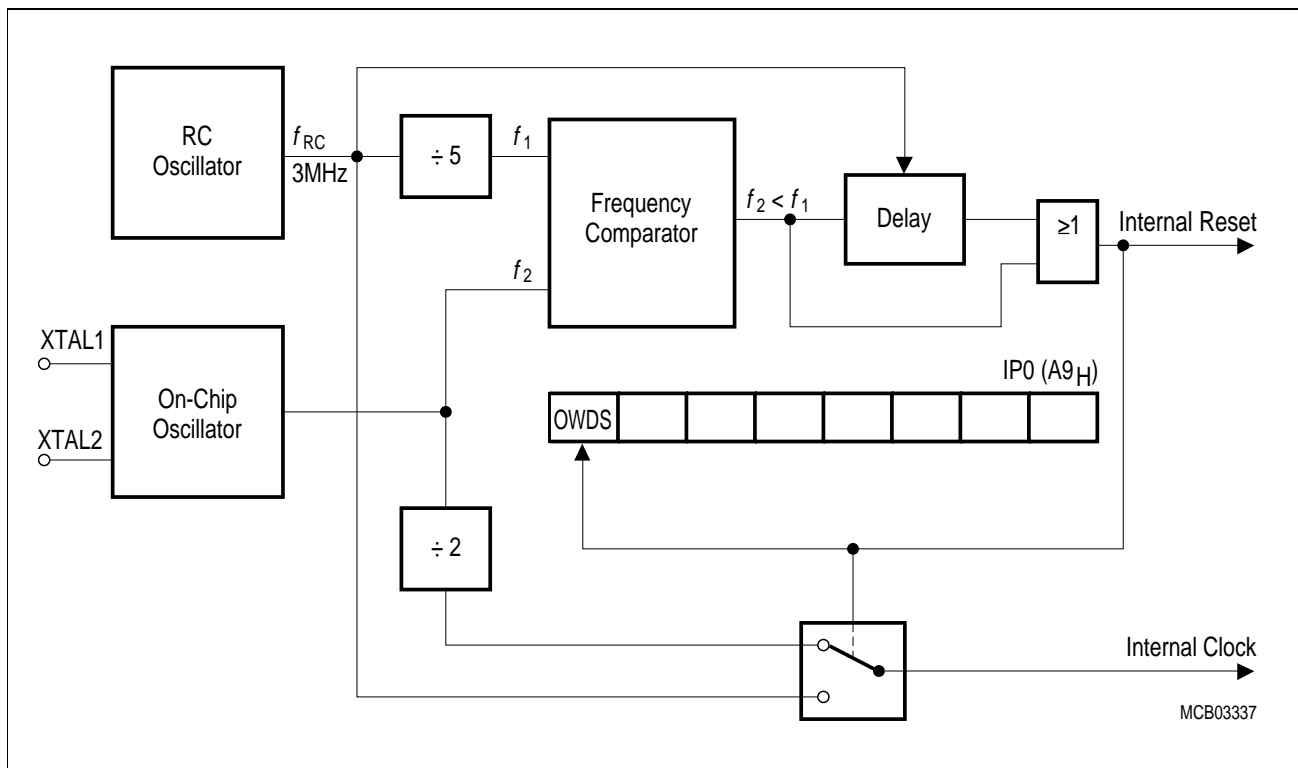
The watchdog supervises the on-chip oscillator’s frequency; if it is lower than the frequency of the auxiliary RC oscillator in the watchdog unit, the internal clock is supplied by the RC oscillator and the device is brought into reset; if the failure condition disappears (i.e. the on-chip oscillator has a higher frequency than the RC oscillator), the part executes a final reset phase of typ. 1 ms in order to allow the oscillator to stabilize; then the oscillator watchdog reset is released and the part starts program execution again.

– **Fast internal reset after power-on**

The oscillator watchdog unit provides a clock supply for the reset before the on-chip oscillator has started. The oscillator watchdog unit also works identically to the monitoring function.

– **Restart from the hardware power down mode.**

If the hardware power down mode is terminated the oscillator watchdog has to control the correct start-up of the on-chip oscillator and to restart the program. The oscillator watchdog function is only part of the complete hardware power down sequence; however, the watchdog works identically to the monitoring function.



**Figure 25**  
**Block Diagram of the Oscillator Watchdog**

## Power Saving Modes

The C517A provides two basic power saving modes, the idle mode and the power down mode. Additionally, a slow down mode is available. This power saving mode reduces the internal clock rate in normal operating mode and it can be also used for further power reduction in idle mode.

- **Idle mode**

The CPU is gated off from the oscillator. All peripherals are still provided with the clock and are able to work. Idle mode is entered by software and can be left by an interrupt or reset.

- **Slow down mode**

The controller keeps up the full operating functionality, but its normal clock frequency is internally divided by 8. This slows down all parts of the controller, the CPU and all peripherals, to 1/8th of their normal operating frequency and also reduces power consumption.

- **Software power down mode**

The operation of the C517A is completely stopped and the oscillator is turned off. This mode is used to save the contents of the internal RAM with a very low standby current. This power down mode is entered by software and can be left by reset.

- **Hardware Power down mode**

If pin  $\overline{\text{HWPD}}$  gets active (low level) the part enters the hardware power down mode and starts a complete internal reset sequence. Thereafter, both oscillators of the chip are stopped and the port pins and several control lines enter a floating state.

In the power down mode of operation,  $V_{\text{DD}}$  can be reduced to minimize power consumption. It must be ensured, however, that  $V_{\text{DD}}$  is not reduced before the power down mode is invoked, and that  $V_{\text{DD}}$  is restored to its normal operating level, before the power down mode is terminated. **Table 12** gives a general overview of the entry and exit procedures of the power saving modes.

**Table 12**  
**Power Saving Modes Overview**

Mode	Entering 2-Instruction Example	Leaving by	Remarks
Idle mode	ORL PCON, #01H ORL PCON, #20H	Ocurrence of an interrupt from a peripheral unit	CPU clock is stopped; CPU maintains their data; peripheral units are active (if enabled) and provided with clock
		Hardware Reset	
Slow Down Mode	In normal mode : ORL PCON,#10H	ANL PCON,#0EFH or Hardware Reset	Internal clock rate is reduced to 1/8 of its nominal frequency
	With idle mode : ORL PCON,#01H ORL PCON, #30H	Ocurrence of an interrupt from a peripheral unit Hardware reset	CPU clock is stopped; CPU maintains their data; peripheral units are active (if enabled) and provided with 1/8 of its nominal frequency
Software Power Down Mode	ORL PCON, #02H ORL PCON, #40H	Hardware Reset	Oscillator is stopped; contents of on-chip RAM and SFR's are maintained;
		Rising edge at $\overline{PE}/SWD$	
Hardware Power Down Mode	$\overline{HWPD} = 0$	$\overline{HWPD} = 1$	Oscillator is stopped; internal reset is executed;

**Absolute Maximum Ratings**

Parameter	Symbol	Limit Values		Unit	Notes
		min.	max.		
Storage temperature	$T_{ST}$	- 65	150	°C	-
Voltage on $V_{DD}$ pins with respect to ground ( $V_{SS}$ )	$V_{DD}$	-0.5	6.5	V	-
Voltage on any pin with respect to ground ( $V_{SS}$ )	$V_{IN}$	-0.5	$V_{DD} + 0.5$	V	-
Input current on any pin during overload condition		-10	10	mA	-
Absolute sum of all input currents during overload condition		-	100	mA	-
Power dissipation	$P_{DISS}$	-	TBD	W	-

**Note:** Stresses above those listed under “Absolute Maximum Ratings” may cause permanent damage of the device. This is a stress rating only and functional operation of the device at these or any other conditions above those indicated in the operational sections of this specification is not implied. Exposure to absolute maximum rating conditions for longer periods may affect device reliability. During absolute maximum rating overload conditions ( $V_{IN} > V_{DD}$  or  $V_{IN} < V_{SS}$ ) the voltage on  $V_{DD}$  pins with respect to ground ( $V_{SS}$ ) must not exceed the values defined by the absolute maximum ratings.

**Operating Conditions**

Parameter	Symbol	Limit Values		Unit	Notes
		min.	max.		
Supply voltage	$V_{DD}$	4.25	5.5	V	-
Ground voltage	$V_{SS}$	0		V	-
Ambient temperature					
SAB-C517A	$T_A$	0	70	°C	18 and 24 MHz
SAF-C517A	$T_A$	-40	85	°C	18 and 24 MHz
SAH-C517A	$T_A$	-40	110	°C	18 MHz
Analog reference voltage	$V_{AREF}$	4	$V_{DD} + 0.1$	V	-
Analog ground voltage	$V_{AGND}$	$V_{SS} - 0.1$	$V_{SS} + 0.2$	V	-
Analog input voltage	$V_{AIN}$	$V_{AGND}$	$V_{AREF}$	V	-
CPU clock	$f_{CPU}$	3.5	24	MHz	-

**DC Characteristics**

(Operating Conditions apply)

Parameter	Symbol	Limit Values		Unit	Test Condition
		min.	max.		
Input low voltage					
Pins except $\overline{EA}$ , $\overline{RESET}$ , $\overline{HWPDP}$	$V_{IL}$	- 0.5	$0.2 V_{DD} - 0.1$	V	-
$\overline{EA}$ pin	$V_{IL1}$	- 0.5	$0.2 V_{DD} - 0.3$	V	-
$\overline{HWPDP}$ and $\overline{RESET}$ pins	$V_{IL2}$	- 0.5	$0.2 V_{DD} + 0.1$	V	-
Input high voltage					
pins except $\overline{RESET}$ , XTAL2 and $\overline{HWPDP}$	$V_{IH}$	$0.2 V_{DD} + 0.9$	$V_{DD} + 0.5$	V	-
XTAL2 pin	$V_{IH1}$	$0.7 V_{DD}$	$V_{DD} + 0.5$	V	-
$\overline{RESET}$ and $\overline{HWPDP}$ pin	$V_{IH2}$	$0.6 V_{DD}$	$V_{DD} + 0.5$	V	-
Output low voltage					
Ports 1, 2, 3, 4, 5, 6	$V_{OL}$	-	0.45	V	$I_{OL} = 1.6 \text{ mA}^1)$
Port 0, $\overline{ALE}$ , $\overline{PSEN}$ , $\overline{RO}$	$V_{OL1}$	-	0.45	V	$I_{OL} = 3.2 \text{ mA}^1)$
Output high voltage					
Ports 1, 2, 3, 4, 5, 6	$V_{OH}$	2.4 $0.9 V_{DD}$	- -	V V	$I_{OH} = - 80 \mu\text{A}$ $I_{OH} = - 10 \mu\text{A}$
Port 0 in external bus mode, $\overline{ALE}$ , $\overline{PSEN}$ , $\overline{RO}$	$V_{OH1}$	2.4 $0.9 V_{DD}$	- -	V V	$I_{OH} = - 800 \mu\text{A}^2)$ $I_{OH} = - 80 \mu\text{A}^2)$
Logic 0 input current					
Ports 1, 2, 3, 4, 5, 6	$I_{LI}$	- 10	- 70	$\mu\text{A}$	$V_{IN} = 2 \text{ V}$
Logical 0-to-1 transition current, Ports 1, 2, 3, 4, 5, 6	$I_{TL}$	- 65	- 650	$\mu\text{A}$	$V_{IN} = 2 \text{ V}$
Input leakage current					
Port 0, 7 and 8, $\overline{EA}$ , $\overline{HWPDP}$	$I_{LI}$	-	$\pm 1$	$\mu\text{A}$	$0.45 < V_{IN} < V_{DD}$
Input low current					
to $\overline{RESET}$ for reset	$I_{IL2}$	- 10	- 100	$\mu\text{A}$	$V_{IN} = 0.45 \text{ V}$
XTAL2	$I_{IL3}$	-	- 15	$\mu\text{A}$	$V_{IN} = 0.45 \text{ V}$
$\overline{PE}/\text{SWD}$ , OWE	$I_{IL4}$	-	- 20	$\mu\text{A}$	$V_{IN} = 0.45 \text{ V}$
Pin capacitance	$C_{IO}$	-	10	pF	$f_C = 1 \text{ MHz}$ , $T_A = 25^\circ\text{C}$
Overload current	$I_{OV}$	-	$\pm 5$	mA	<sup>7) 8)</sup>

Notes see next page

**Power Supply Current**

Parameter		Symbol	Limit Values		Unit	Test Condition
			typ. <sup>9)</sup>	max. <sup>10)</sup>		
Active mode	18 MHz	$I_{DD}$	21.3	29.2	mA	<sup>4)</sup>
	24 MHz	$I_{DD}$	27.3	37.6	mA	
Idle mode	18 MHz	$I_{DD}$	11.6	16.2	mA	<sup>5)</sup>
	24 MHz	$I_{DD}$	14.6	20.4	mA	
Active mode with slow-down enabled	18 MHz	$I_{DD}$	9.5	13.1	mA	<sup>6)</sup>
	24 MHz	$I_{DD}$	10.7	14.9	mA	
Power-down mode		$I_{PD}$	15	50	$\mu$ A	$V_{DD} = 2 \dots 5.5 \text{ V}^{3)}$

**Notes:**

- 1) Capacitive loading on ports 0 and 2 may cause spurious noise pulses to be superimposed on the  $V_{OL}$  of ALE and port 3. The noise is due to external bus capacitance discharging into the port 0 and port 2 pins when these pins make 1-to-0 transitions during bus operation. In the worst case (capacitive loading > 100 pF), the noise pulse on ALE line may exceed 0.8 V. In such cases it may be desirable to qualify ALE with a schmitt-trigger, or use an address latch with a schmitt-trigger strobe input.
- 2) Capacitive loading on ports 0 and 2 may cause the  $V_{OH}$  on ALE and  $\overline{\text{PSEN}}$  to momentarily fall below the 0.9  $V_{DD}$  specification when the address lines are stabilizing.
- 3)  $I_{PD}$  (power-down mode) is measured under following conditions:  
 $\overline{\text{EA}} = \overline{\text{RESET}} = \text{Port 0} = \text{Port 7} = \text{Port 8} = V_{DD}$ ; XTAL1 = N.C.; XTAL2 =  $V_{SS}$ ;  $\overline{\text{PE}}/\text{SWD} = \text{OWE} = V_{SS}$ ; HWPDP =  $V_{DD}$  for software power-down mode;  $V_{AGND} = V_{SS}$ ;  $V_{AREF} = V_{DD}$ ; all other pins are disconnected.  
 $I_{PD}$  (hardware power-down mode) is independent of any particular pin connection.
- 4)  $I_{DD}$  (active mode) is measured with:  
 XTAL2 driven with  $t_{CLCH}$ ,  $t_{CHCL} = 5 \text{ ns}$ ,  $V_{IL} = V_{SS} + 0.5 \text{ V}$ ,  $V_{IH} = V_{DD} - 0.5 \text{ V}$ ; XTAL1 = N.C.;  
 $\overline{\text{EA}} = \overline{\text{PE}}/\text{SWD} = V_{SS}$ ; Port 0 = Port 7 = Port 8 =  $V_{DD}$ ; HWPDP =  $V_{DD}$ ; RESET =  $V_{DD}$ ; all other pins are disconnected.
- 5)  $I_{DD}$  (idle mode) is measured with all output pins disconnected and with all peripherals disabled;  
 XTAL2 driven with  $t_{CLCH}$ ,  $t_{CHCL} = 5 \text{ ns}$ ,  $V_{IL} = V_{SS} + 0.5 \text{ V}$ ,  $V_{IH} = V_{DD} - 0.5 \text{ V}$ ; XTAL1 = N.C.;  
 RESET =  $V_{DD}$ ; HWPDP = Port 0 = Port 7 = Port 8 =  $V_{DD}$ ;  $\overline{\text{EA}} = \overline{\text{PE}}/\text{SWD} = V_{SS}$ ; all other pins are disconnected;
- 6)  $I_{DD}$  (active mode with slow-down mode) is measured with all output pins disconnected and with all peripherals disabled; XTAL2 driven with  $t_{CLCH}$ ,  $t_{CHCL} = 5 \text{ ns}$ ,  $V_{IL} = V_{SS} + 0.5 \text{ V}$ ,  $V_{IH} = V_{DD} - 0.5 \text{ V}$ ; XTAL1 = N.C.;  
 HWPDP =  $V_{DD}$ ; RESET =  $V_{DD}$ ; Port 7 = Port 8 =  $V_{DD}$ ;  $\overline{\text{EA}} = \overline{\text{PE}}/\text{SWD} = V_{SS}$ ; all other pins are disconnected.
- 7) Overload conditions under operating conditions occur if the voltage on the respective pin exceeds the specified operating range (i.e.  $V_{OV} > V_{DD} + 0.5 \text{ V}$  or  $V_{OV} < V_{SS} - 0.5 \text{ V}$ ). The absolute sum of input currents on all port pins may not exceed 50 mA. The supply voltage  $V_{DD}$  and  $V_{SS}$  must remain within the specified limits.
- 8) Not 100% tested, guaranteed by design characterization
- 9) The typical  $I_{DD}$  values are periodically measured at  $T_A = +25 \text{ }^\circ\text{C}$  and  $V_{DD} = 5 \text{ V}$  but not 100% tested.
- 10) The maximum  $I_{DD}$  values are measured under worst case conditions ( $T_A = 0 \text{ }^\circ\text{C}$  or  $-40 \text{ }^\circ\text{C}$  and  $V_{DD} = 5.5 \text{ V}$ )



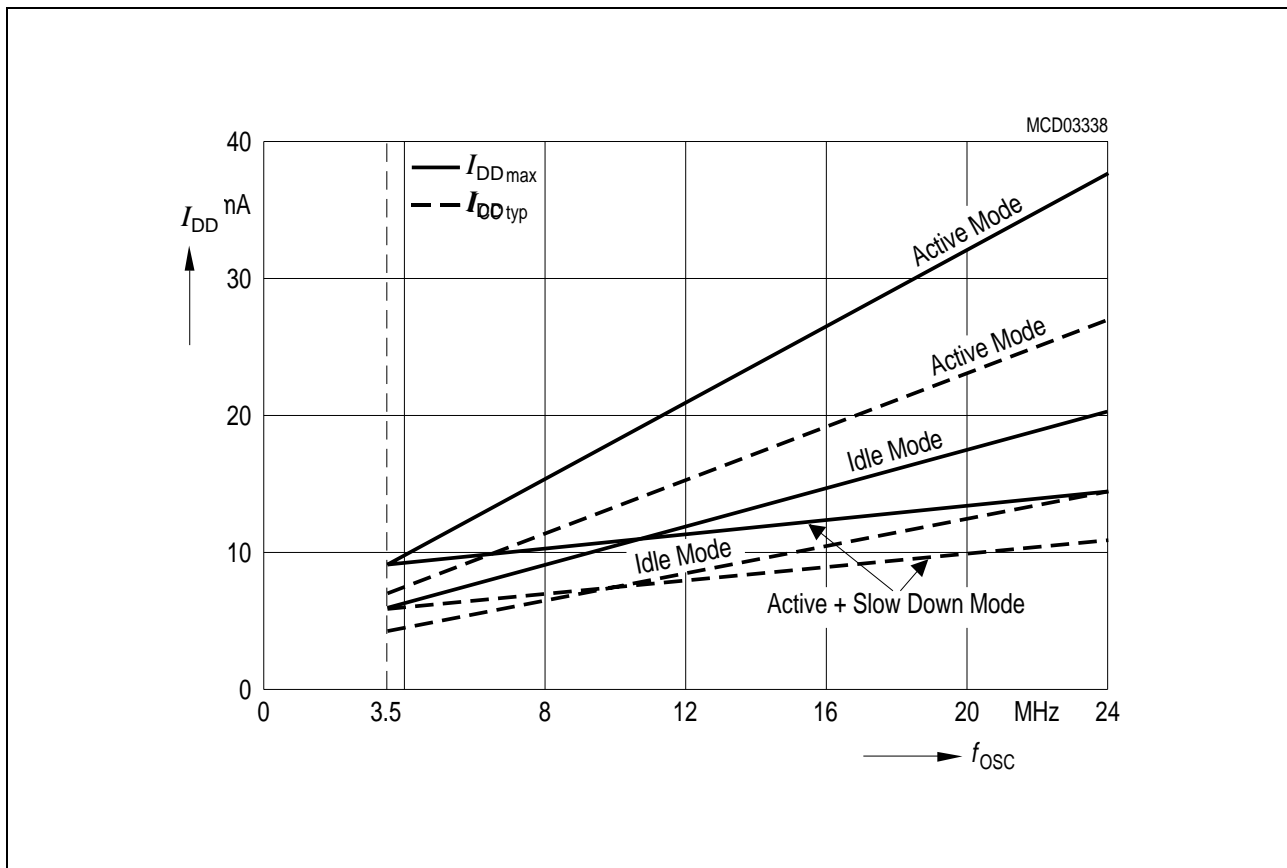


Figure 26  
IDD Diagram

Table 13  
Power Supply Current Calculation Formulas

Parameter	Symbol	Formula
Active mode	$I_{DD\ typ}$	$1 * f_{OSC} + 3.3$
	$I_{DD\ max}$	$1.4 * f_{OSC} + 4.0$
Idle mode	$I_{DD\ typ}$	$0.5 * f_{OSC} + 2.6$
	$I_{DD\ max}$	$0.7 * f_{OSC} + 3.6$
Active mode with slow-down enabled	$I_{DD\ typ}$	$0.25 * f_{OSC} + 4.95$
	$I_{DD\ max}$	$0.3 * f_{OSC} + 7.7$

Note :  $f_{osc}$  is the oscillator frequency in MHz.  $I_{DD}$  values are given in mA.

## A/D Converter Characteristics

(Operating Conditions apply)

Parameter	Symbol	Limit Values		Unit	Test Condition
		min.	max.		
Analog input voltage	$V_{AIN}$	$V_{AGND}$	$V_{AREF}$	V	1)
Sample time	$t_S$	–	$16 \times t_{IN}$ $8 \times t_{IN}$	ns	Prescaler ÷ 8 Prescaler ÷ 4 2)
Conversion cycle time	$t_{ADCC}$	–	$96 \times t_{IN}$ $48 \times t_{IN}$	ns	Prescaler ÷ 8 Prescaler ÷ 4 3)
Total unadjusted error	$T_{UE}$	–	$\pm 2$	LSB	$V_{SS}+0.5V \leq V_{IN} \leq V_{DD}-0.5V$ 4)
Internal resistance of reference voltage source	$R_{AREF}$	–	$t_{ADC} / 250$ - 0.25	k $\Omega$	$t_{ADC}$ in [ns] 5) 6)
Internal resistance of analog source	$R_{ASRC}$	–	$t_S / 500$ - 0.25	k $\Omega$	$t_S$ in [ns] 2) 6)
ADC input capacitance	$C_{AIN}$	–	50	pF	6)

Notes see next page.

### Clock calculation table :

Clock Prescaler Ratio	ADCL	$t_{ADC}$	$t_S$	$t_{ADCC}$
÷ 8	1	$8 \times t_{IN}$	$16 \times t_{IN}$	$96 \times t_{IN}$
÷ 4	0	$4 \times t_{IN}$	$8 \times t_{IN}$	$48 \times t_{IN}$

Further timing conditions :  $t_{ADC} \text{ min} = 500 \text{ ns}$   
 $t_{IN} = 2 / f_{OSC} = 2 t_{CLCL}$

**Notes:**

- 1)  $V_{AIN}$  may exceed  $V_{AGND}$  or  $V_{AREF}$  up to the absolute maximum ratings. However, the conversion result in these cases will be  $X000_H$  or  $X3FF_H$ , respectively.
- 2) During the sample time the input capacitance  $C_{AIN}$  can be charged/discharged by the external source. The internal resistance of the analog source must allow the capacitance to reach their final voltage level within  $t_S$ . After the end of the sample time  $t_S$ , changes of the analog input voltage have no effect on the conversion result.
- 3) This parameter includes the sample time  $t_S$ , the time for determining the digital result and the time for the calibration. Values for the conversion clock  $t_{ADC}$  depend on programming and can be taken from the table on the previous page.
- 4)  $T_{UE}$  is tested at  $V_{AREF} = 5.0\text{ V}$ ,  $V_{AGND} = 0\text{ V}$ ,  $V_{DD} = 4.9\text{ V}$ . It is guaranteed by design characterization for all other voltages within the defined voltage range.  
If an overload condition occurs on maximum 2 not selected analog input pins and the absolute sum of input overload currents on all analog input pins does not exceed 10 mA, an additional conversion error of 1/2 LSB is permissible.
- 5) During the conversion the ADC's capacitance must be repeatedly charged or discharged. The internal resistance of the reference source must allow the capacitance to reach their final voltage level within the indicated time. The maximum internal resistance results from the programmed conversion timing.
- 6) Not 100% tested, but guaranteed by design characterization.

## AC Characteristics (18 MHz)

(Operating Conditions apply)

( $C_L$  for port 0, ALE and  $\overline{\text{PSEN}}$  outputs = 100 pF;  $C_L$  for all other outputs = 80 pF)

## Program Memory Characteristics

Parameter	Symbol	Limit Values				Unit
		18 MHz Clock		Variable Clock $1/t_{\text{CLCL}} = 3.5 \text{ MHz to } 18 \text{ MHz}$		
		min.	max.	min.	max.	
ALE pulse width	$t_{\text{LHLL}}$	71	–	$2 t_{\text{CLCL}} - 40$	–	ns
Address setup to ALE	$t_{\text{AVLL}}$	26	–	$t_{\text{CLCL}} - 30$	–	ns
Address hold after ALE	$t_{\text{LLAX}}$	26	–	$t_{\text{CLCL}} - 30$	–	ns
ALE low to valid instruction in	$t_{\text{LLIV}}$	–	122	–	$4 t_{\text{CLCL}} - 100$	ns
ALE to $\overline{\text{PSEN}}$	$t_{\text{LLPL}}$	31	–	$t_{\text{CLCL}} - 25$	–	ns
$\overline{\text{PSEN}}$ pulse width	$t_{\text{PLPH}}$	132	–	$3 t_{\text{CLCL}} - 35$	–	ns
$\overline{\text{PSEN}}$ to valid instruction in	$t_{\text{PLIV}}$	–	92	–	$3 t_{\text{CLCL}} - 75$	ns
Input instruction hold after $\overline{\text{PSEN}}$	$t_{\text{PXIX}}$	0	–	0	–	ns
Input instruction float after $\overline{\text{PSEN}}$	$t_{\text{PXIZ}}^*)$	–	46	–	$t_{\text{CLCL}} - 10$	ns
Address valid after $\overline{\text{PSEN}}$	$t_{\text{PXAV}}^*)$	48	–	$t_{\text{CLCL}} - 8$	–	ns
Address to valid instr in	$t_{\text{AVIV}}$	–	180	–	$5 t_{\text{CLCL}} - 98$	ns
Address float to $\overline{\text{PSEN}}$	$t_{\text{AZPL}}$	0	–	0	–	ns

<sup>\*)</sup> Interfacing the C517A to devices with float times up to 45 ns is permissible. This limited bus contention will not cause any damage to port 0 drivers.

## CLKOUT Characteristics

Parameter	Symbol	Limit Values				Unit
		18 MHz Clock		Variable Clock $1/t_{\text{CLCL}} = 3.5 \text{ MHz to } 18 \text{ MHz}$		
		min.	max.	min.	max.	
ALE to CLKOUT	$t_{\text{LLSH}}$	349	–	$7 t_{\text{CLCL}} - 40$	–	ns
CLKOUT high time	$t_{\text{SHSL}}$	71	–	$2 t_{\text{CLCL}} - 40$	–	ns
CLKOUT low time	$t_{\text{SLSH}}$	516	–	$10 t_{\text{CLCL}} - 40$	–	ns
CLKOUT low to ALE high	$t_{\text{SLLH}}$	16	96	$t_{\text{CLCL}} - 40$	$t_{\text{CLCL}} + 40$	ns

AC Characteristics (18 MHz, cont'd)

External Data Memory Characteristics

Parameter	Symbol	Limit Values				Unit
		18 MHz Clock		Variable Clock $1/t_{CLCL} = 3.5 \text{ MHz to } 18 \text{ MHz}$		
		min.	max.	min.	max.	
$\overline{RD}$ pulse width	$t_{RLRH}$	233	–	$6 t_{CLCL} - 100$	–	ns
$\overline{WR}$ pulse width	$t_{WLWH}$	233	–	$6 t_{CLCL} - 100$	–	ns
Address hold after ALE	$t_{LLAX2}$	81	–	$2 t_{CLCL} - 30$	–	ns
$\overline{RD}$ to valid data in	$t_{RLDV}$	–	128	–	$5 t_{CLCL} - 150$	ns
Data hold after $\overline{RD}$	$t_{RHDX}$	0	–	0	–	ns
Data float after $\overline{RD}$	$t_{RHDZ}$	–	51	–	$2 t_{CLCL} - 60$	ns
ALE to valid data in	$t_{LLDV}$	–	294	–	$8 t_{CLCL} - 150$	ns
Address to valid data in	$t_{AVDV}$	–	335	–	$9 t_{CLCL} - 165$	ns
ALE to $\overline{WR}$ or $\overline{RD}$	$t_{LLWL}$	117	217	$3 t_{CLCL} - 50$	$3 t_{CLCL} + 50$	ns
Address valid to $\overline{WR}$ or $\overline{RD}$	$t_{AVWL}$	92	–	$4 t_{CLCL} - 130$	–	ns
$\overline{WR}$ or $\overline{RD}$ high to ALE high	$t_{WHLH}$	16	96	$t_{CLCL} - 40$	$t_{CLCL} + 40$	ns
Data valid to $\overline{WR}$ transition	$t_{QVWX}$	11	–	$t_{CLCL} - 45$	–	ns
Data setup before $\overline{WR}$	$t_{QVWH}$	239	–	$7 t_{CLCL} - 150$	–	ns
Data hold after $\overline{WR}$	$t_{WHQX}$	16	–	$t_{CLCL} - 40$	–	ns
Address float after $\overline{RD}$	$t_{RLAZ}$	–	0	–	0	ns

External Clock Drive Characteristics

Parameter	Symbol	Limit Values		Unit
		Variable Clock Freq. = 3.5 MHz to 18 MHz		
		min.	max.	
Oscillator period	$t_{CLCL}$	55.6	285.7	ns
High time	$t_{CHCX}$	15	$t_{CLCL} - t_{CLCX}$	ns
Low time	$t_{CLCX}$	15	$t_{CLCL} - t_{CHCX}$	ns
Rise time	$t_{CLCH}$	–	15	ns
Fall time	$t_{CHCL}$	–	15	ns

## AC Characteristics (24 MHz)

(Operating Conditions apply)

( $C_L$  for port 0, ALE and  $\overline{\text{PSEN}}$  outputs = 100 pF;  $C_L$  for all other outputs = 80 pF)

## Program Memory Characteristics

Parameter	Symbol	Limit Values				Unit
		24 MHz Clock		Variable Clock $1/t_{\text{CLCL}} = 3.5 \text{ MHz to } 24 \text{ MHz}$		
		min.	max.	min.	max.	
ALE pulse width	$t_{\text{LHLL}}$	43	–	$2 t_{\text{CLCL}} - 40$	–	ns
Address setup to ALE	$t_{\text{AVLL}}$	17	–	$t_{\text{CLCL}} - 25$	–	ns
Address hold after ALE	$t_{\text{LLAX}}$	17	–	$t_{\text{CLCL}} - 25$	–	ns
ALE low to valid instruction in	$t_{\text{LLIV}}$	–	80	–	$4 t_{\text{CLCL}} - 87$	ns
ALE to $\overline{\text{PSEN}}$	$t_{\text{LLPL}}$	22	–	$t_{\text{CLCL}} - 20$	–	ns
$\overline{\text{PSEN}}$ pulse width	$t_{\text{PLPH}}$	95	–	$3t_{\text{CLCL}} - 30$	–	ns
$\overline{\text{PSEN}}$ to valid instruction in	$t_{\text{PLIV}}$	–	60	–	$3 t_{\text{CLCL}} - 65$	ns
Input instruction hold after $\overline{\text{PSEN}}$	$t_{\text{PXIX}}$	0	–	0	–	ns
Input instruction float after $\overline{\text{PSEN}}$	$t_{\text{PXIZ}}^*)$	–	32	–	$t_{\text{CLCL}} - 10$	ns
Address valid after $\overline{\text{PSEN}}$	$t_{\text{PXAV}}^*)$	37	–	$t_{\text{CLCL}} - 5$	–	ns
Address to valid instr in	$t_{\text{AVIV}}$	–	148	–	$5 t_{\text{CLCL}} - 60$	ns
Address float to $\overline{\text{PSEN}}$	$t_{\text{AZPL}}$	0	–	0	–	ns

<sup>\*)</sup> Interfacing the C517A to devices with float times up to 37 ns is permissible. This limited bus contention will not cause any damage to port 0 drivers.

## CLKOUT Characteristics

Parameter	Symbol	Limit Values				Unit
		24 MHz Clock		Variable Clock $1/t_{\text{CLCL}} = 3.5 \text{ MHz to } 24 \text{ MHz}$		
		min.	max.	min.	max.	
ALE to CLKOUT	$t_{\text{LLSH}}$	252	–	$7 t_{\text{CLCL}} - 40$	–	ns
CLKOUT high time	$t_{\text{SHSL}}$	43	–	$2 t_{\text{CLCL}} - 40$	–	ns
CLKOUT low time	$t_{\text{SLSH}}$	377	–	$10 t_{\text{CLCL}} - 40$	–	ns
CLKOUT low to ALE high	$t_{\text{SLLH}}$	2	82	$t_{\text{CLCL}} - 40$	$t_{\text{CLCL}} + 40$	ns

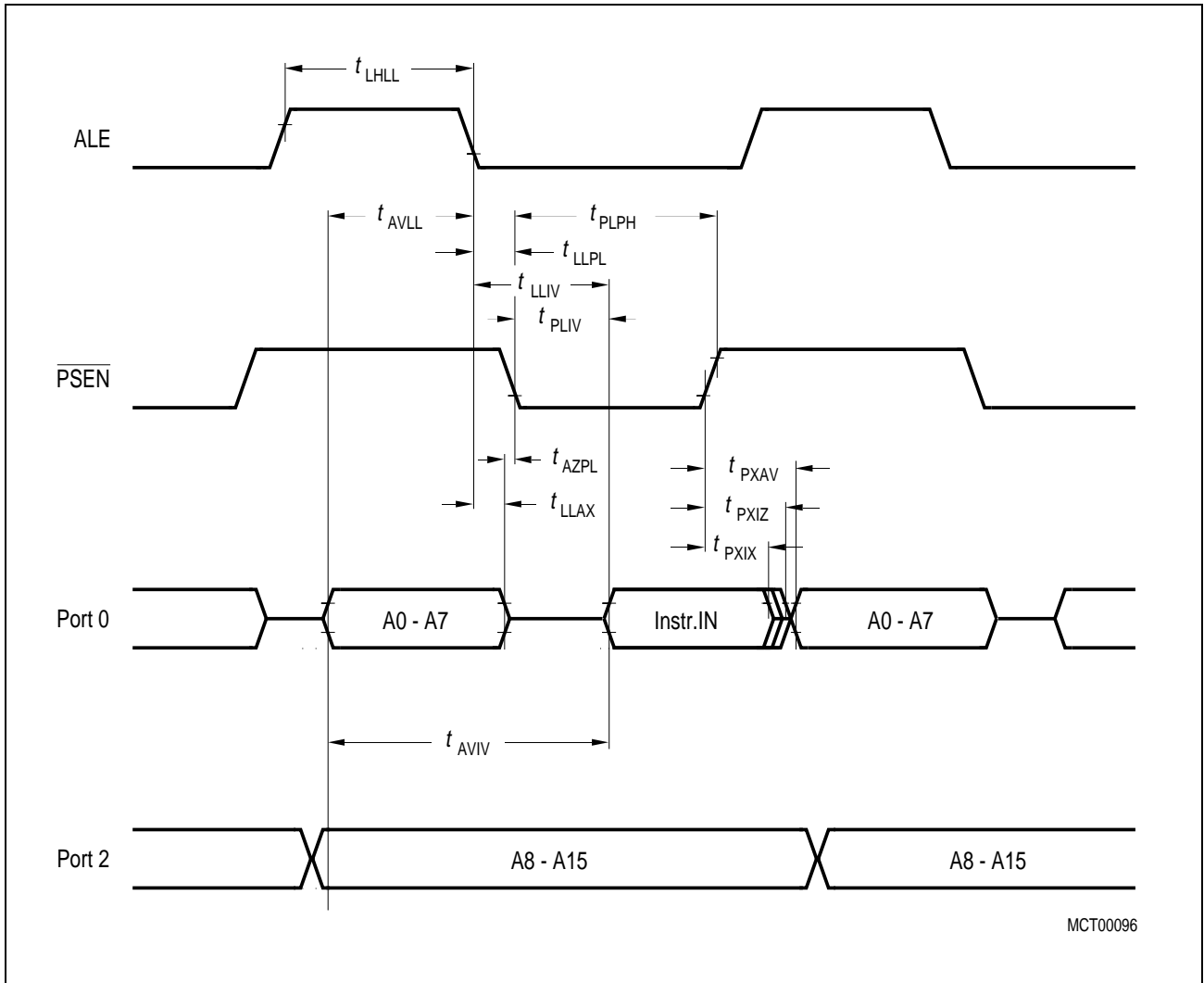
AC Characteristics (24 MHz, cont'd)

External Data Memory Characteristics

Parameter	Symbol	Limit Values				Unit
		24 MHz Clock		Variable Clock $1/t_{CLCL} = 3.5 \text{ MHz to } 24 \text{ MHz}$		
		min.	max.	min.	max.	
$\overline{RD}$ pulse width	$t_{RLRH}$	180	–	$6 t_{CLCL} - 70$	–	ns
$\overline{WR}$ pulse width	$t_{WLWH}$	180	–	$6 t_{CLCL} - 70$	–	ns
Address hold after ALE	$t_{LLAX2}$	53	–	$2 t_{CLCL} - 30$	–	ns
$\overline{RD}$ to valid data in	$t_{RLDV}$	–	118	–	$5 t_{CLCL} - 90$	ns
Data hold after $\overline{RD}$	$t_{RHDX}$	0	–	0	–	ns
Data float after $\overline{RD}$	$t_{RHDZ}$	–	63	–	$2 t_{CLCL} - 20$	ns
ALE to valid data in	$t_{LLDV}$	–	200	–	$8 t_{CLCL} - 133$	ns
Address to valid data in	$t_{AVDV}$	–	220	–	$9 t_{CLCL} - 155$	ns
ALE to $\overline{WR}$ or $\overline{RD}$	$t_{LLWL}$	75	175	$3 t_{CLCL} - 50$	$3 t_{CLCL} + 50$	ns
Address valid to $\overline{WR}$ or $\overline{RD}$	$t_{AVWL}$	67	–	$4 t_{CLCL} - 97$	–	ns
$\overline{WR}$ or $\overline{RD}$ high to ALE high	$t_{WHLH}$	17	67	$t_{CLCL} - 25$	$t_{CLCL} + 25$	ns
Data valid to $\overline{WR}$ transition	$t_{QVWX}$	5	–	$t_{CLCL} - 37$	–	ns
Data setup before $\overline{WR}$	$t_{QVWH}$	170	–	$7 t_{CLCL} - 122$	–	ns
Data hold after $\overline{WR}$	$t_{WHQX}$	15	–	$t_{CLCL} - 27$	–	ns
Address float after $\overline{RD}$	$t_{RLAZ}$	–	0	–	0	ns

External Clock Drive Characteristics

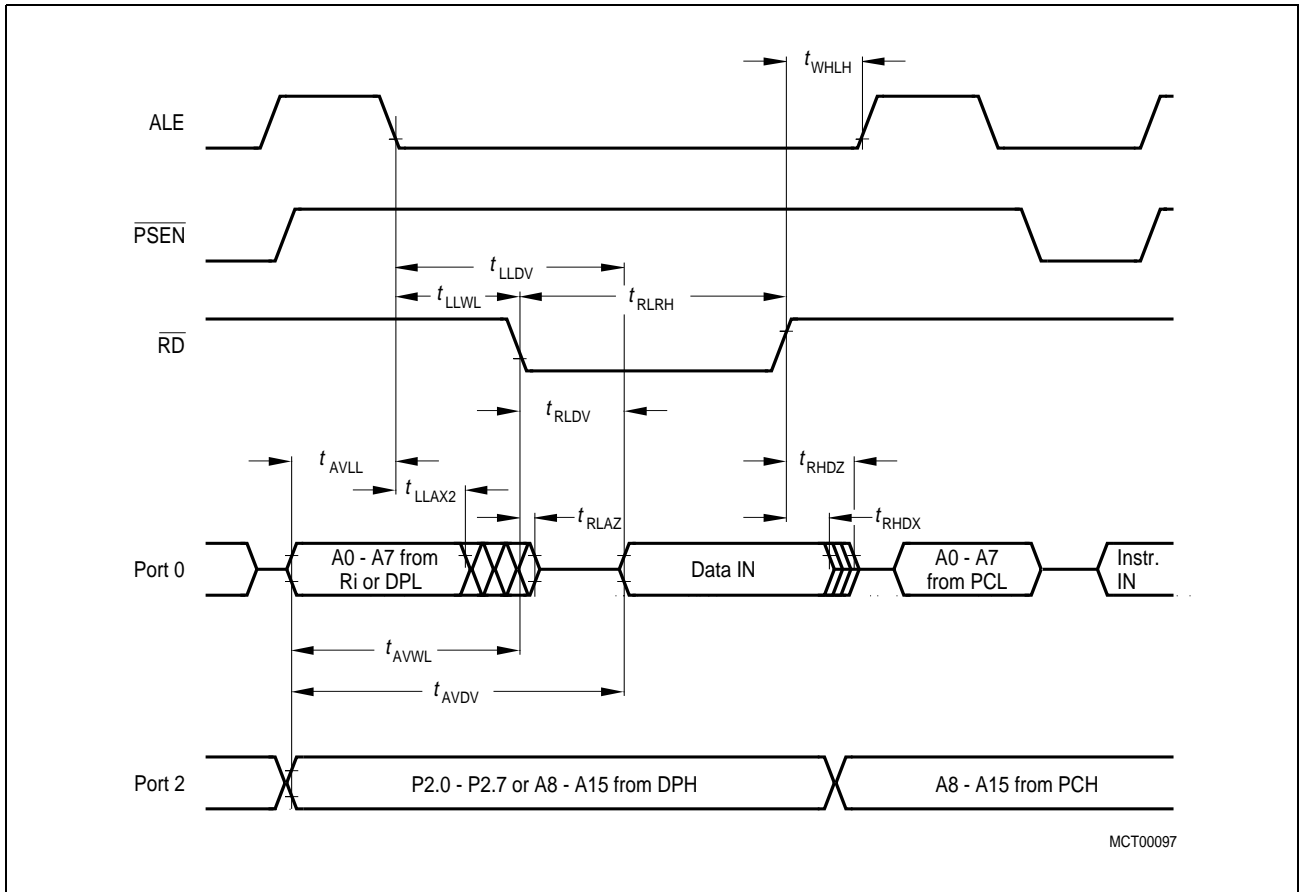
Parameter	Symbol	Limit Values		Unit
		Variable Clock Freq. = 3.5 MHz to 24 MHz		
		min.	max.	
Oscillator period	$t_{CLCL}$	41.7	285.7	ns
High time	$t_{CHCX}$	12	$t_{CLCL} - t_{CLCX}$	ns
Low time	$t_{CLCX}$	12	$t_{CLCL} - t_{CHCX}$	ns
Rise time	$t_{CLCH}$	–	12	ns
Fall time	$t_{CHCL}$	–	12	ns



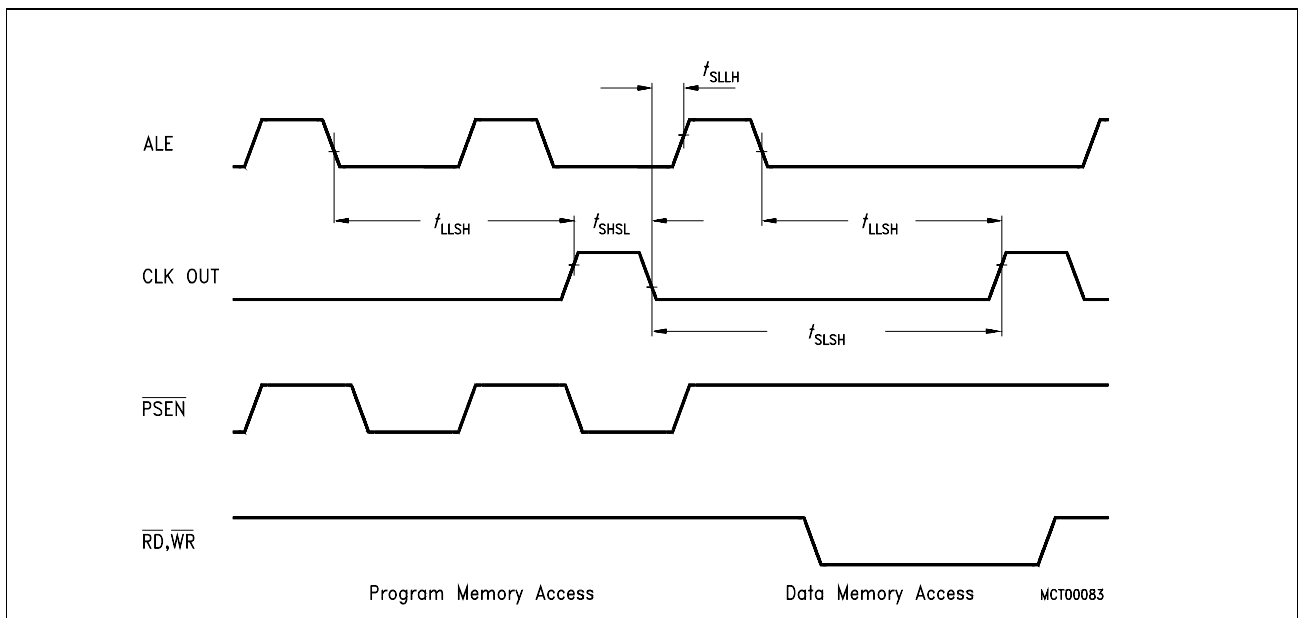
MCT00096

**Figure 27**  
**Program Memory Read Cycle**

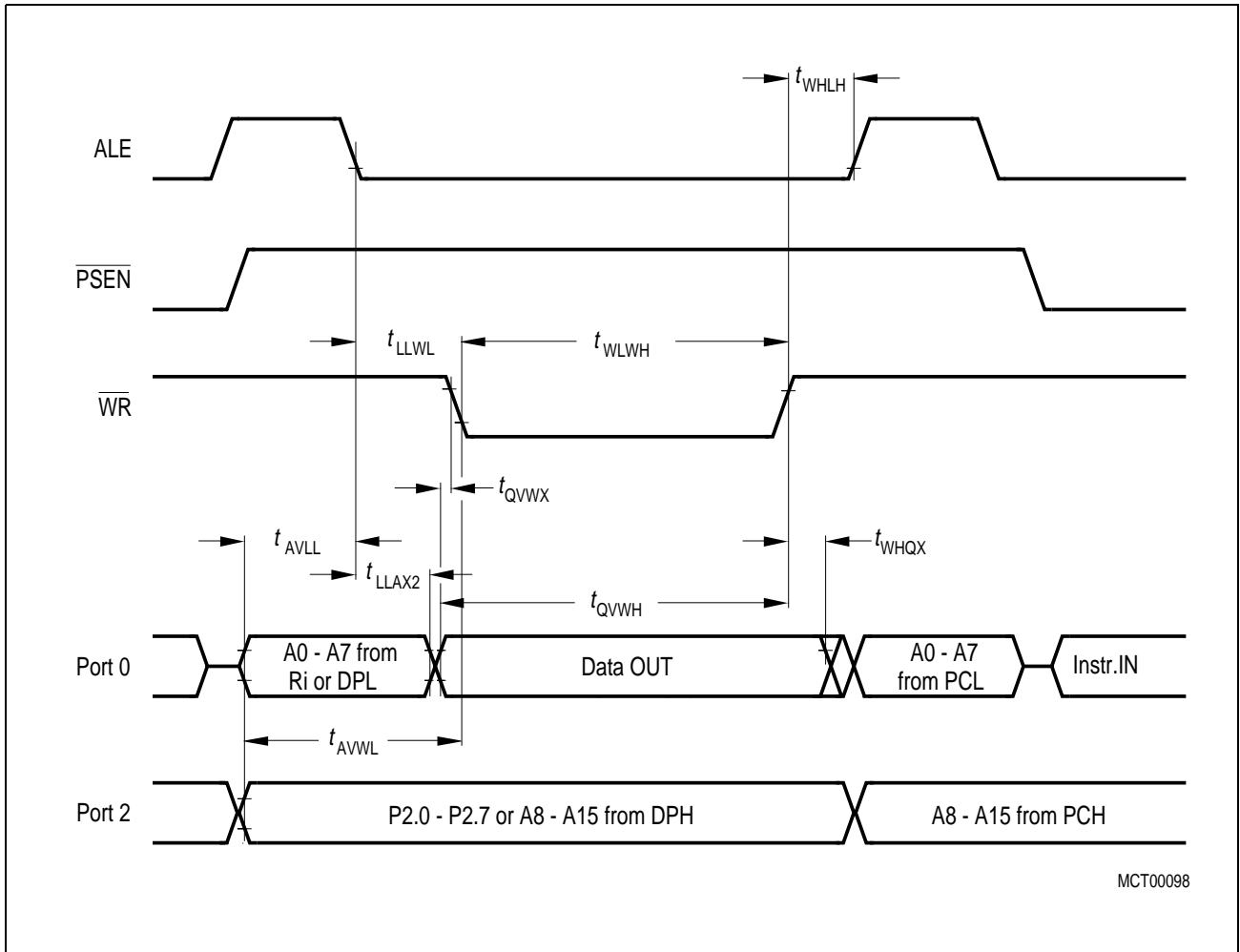




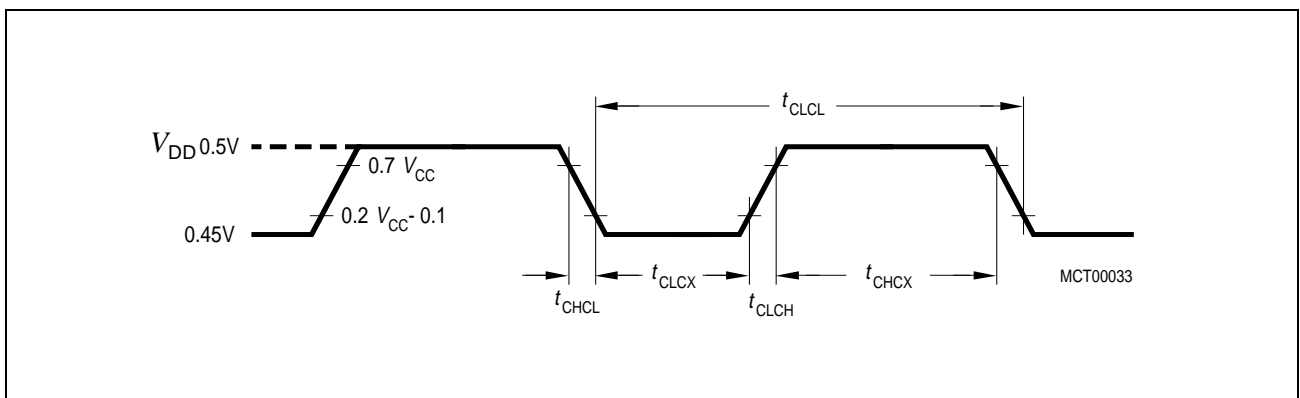
**Figure 28**  
Data Memory Read Cycle



**Figure 29**  
CLKOUT Timing



**Figure 30**  
Data Memory Write Cycle



**Figure 31**  
External Clock Drive on XTAL2

ROM Verification Characteristics for the C517A-4RM/4RN

ROM Verification Mode 1

Parameter	Symbol	Limit Values		Unit
		min.	max.	
Address to valid data	$t_{AVQV}$	–	$10 t_{CLCL}$	ns

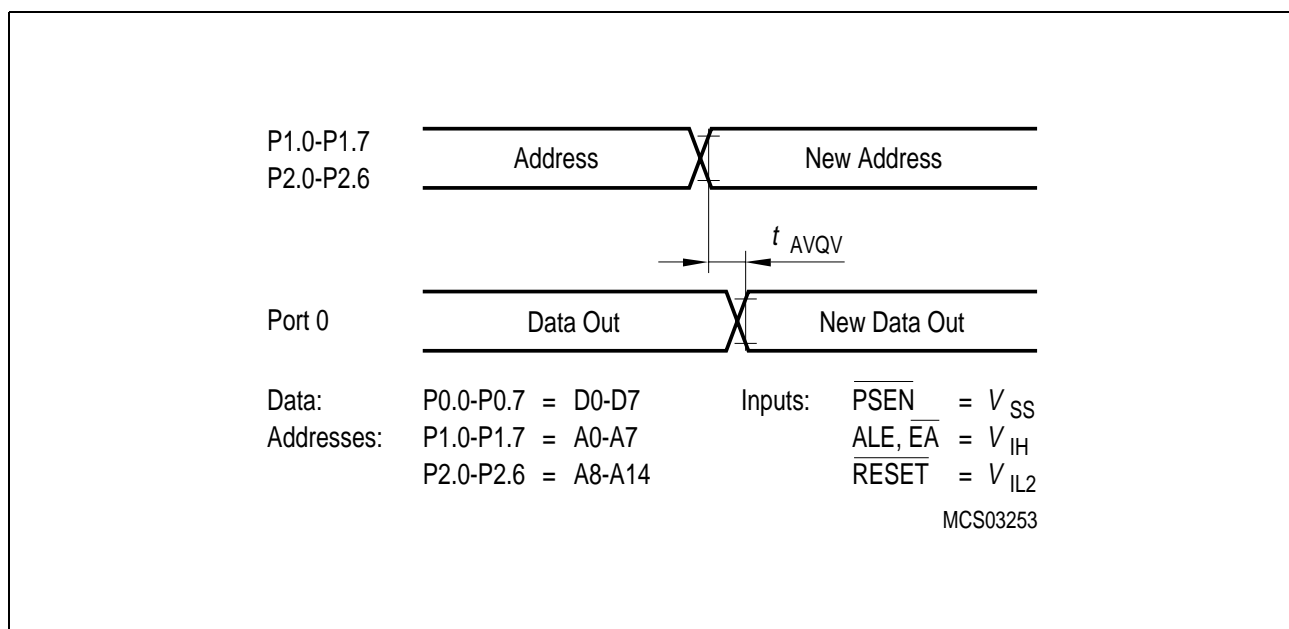


Figure 32  
ROM Verification Mode 1

ROM Verification Mode 2

Parameter	Symbol	Limit Values			Unit
		min.	typ	max.	
ALE pulse width	$t_{AWD}$	–	$2 t_{CLCL}$	–	ns
ALE period	$t_{ACY}$	–	$12 t_{CLCL}$	–	ns
Data valid after ALE	$t_{DVA}$	–	–	$4 t_{CLCL}$	ns
Data stable after ALE	$t_{DSA}$	$8 t_{CLCL}$	–	–	ns
P3.5 setup to ALE low	$t_{AS}$	–	$t_{CLCL}$	–	ns
Oscillator frequency	$1/ t_{CLCL}$	3.5	–	24	MHz

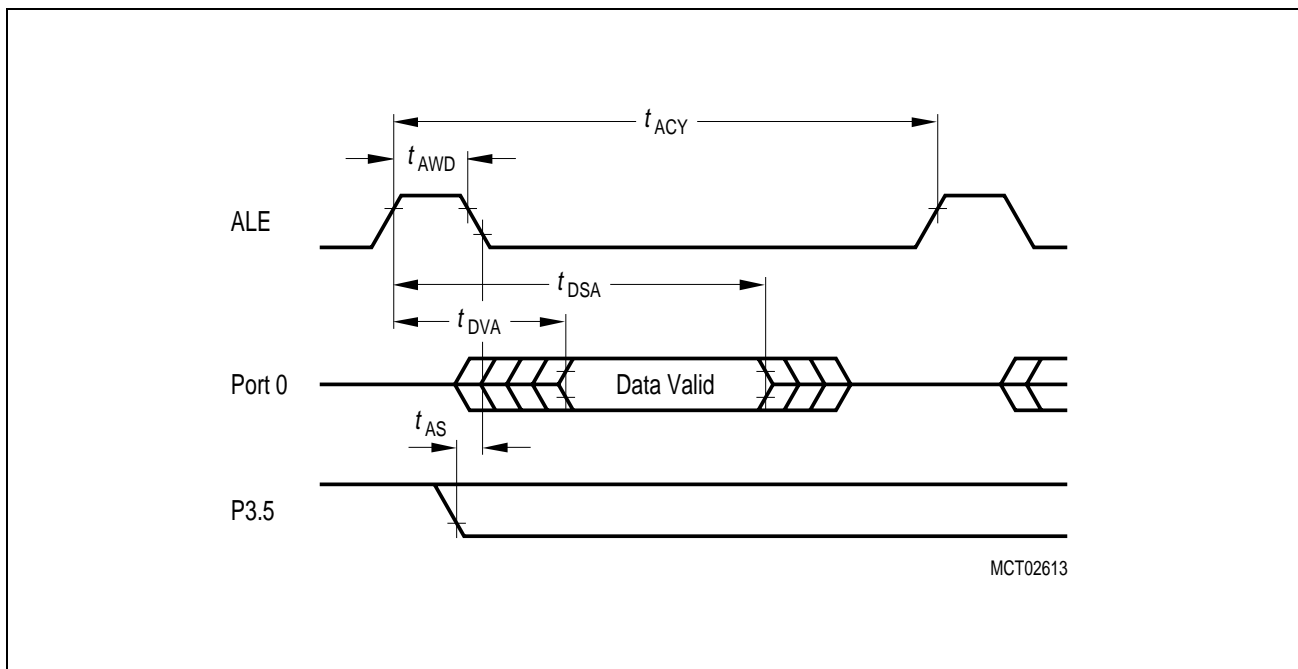
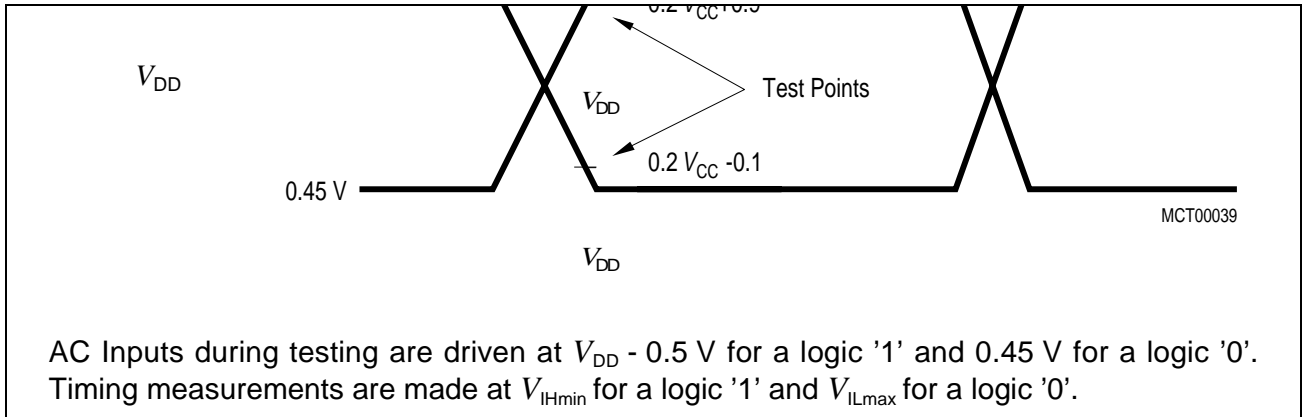
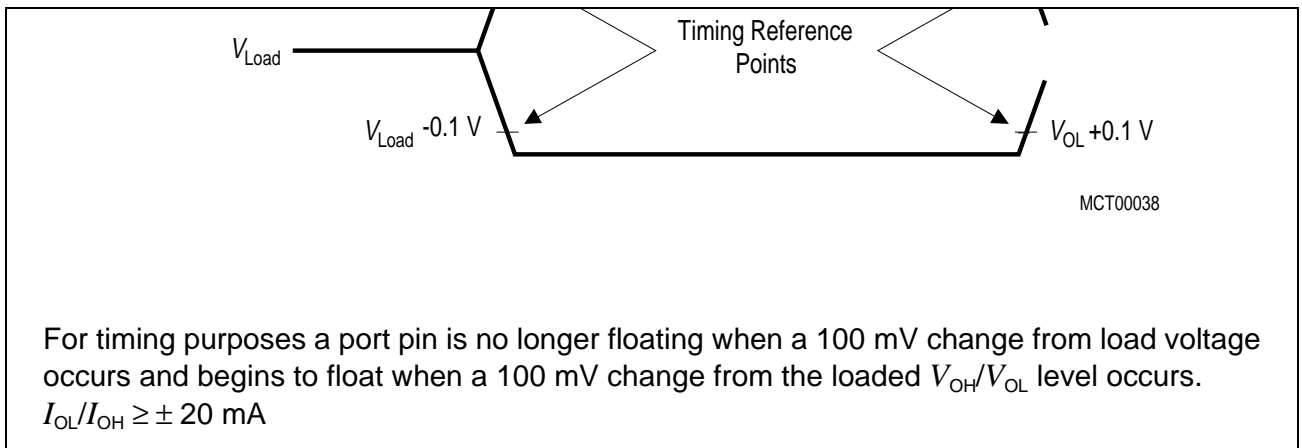


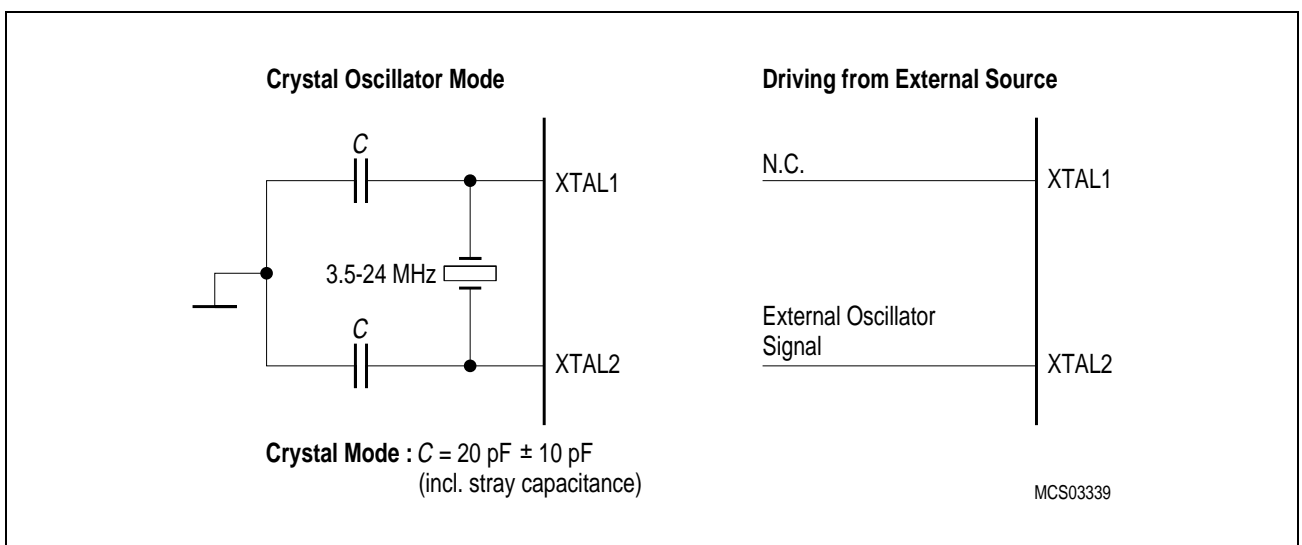
Figure 33  
ROM Verification Mode 2



**Figure 34**  
**AC Testing: Input, Output Waveforms**



**Figure 35**  
**AC Testing : Float Waveforms**



**Figure 36**  
**Recommended Oscillator Circuits for Crystal Oscillator**

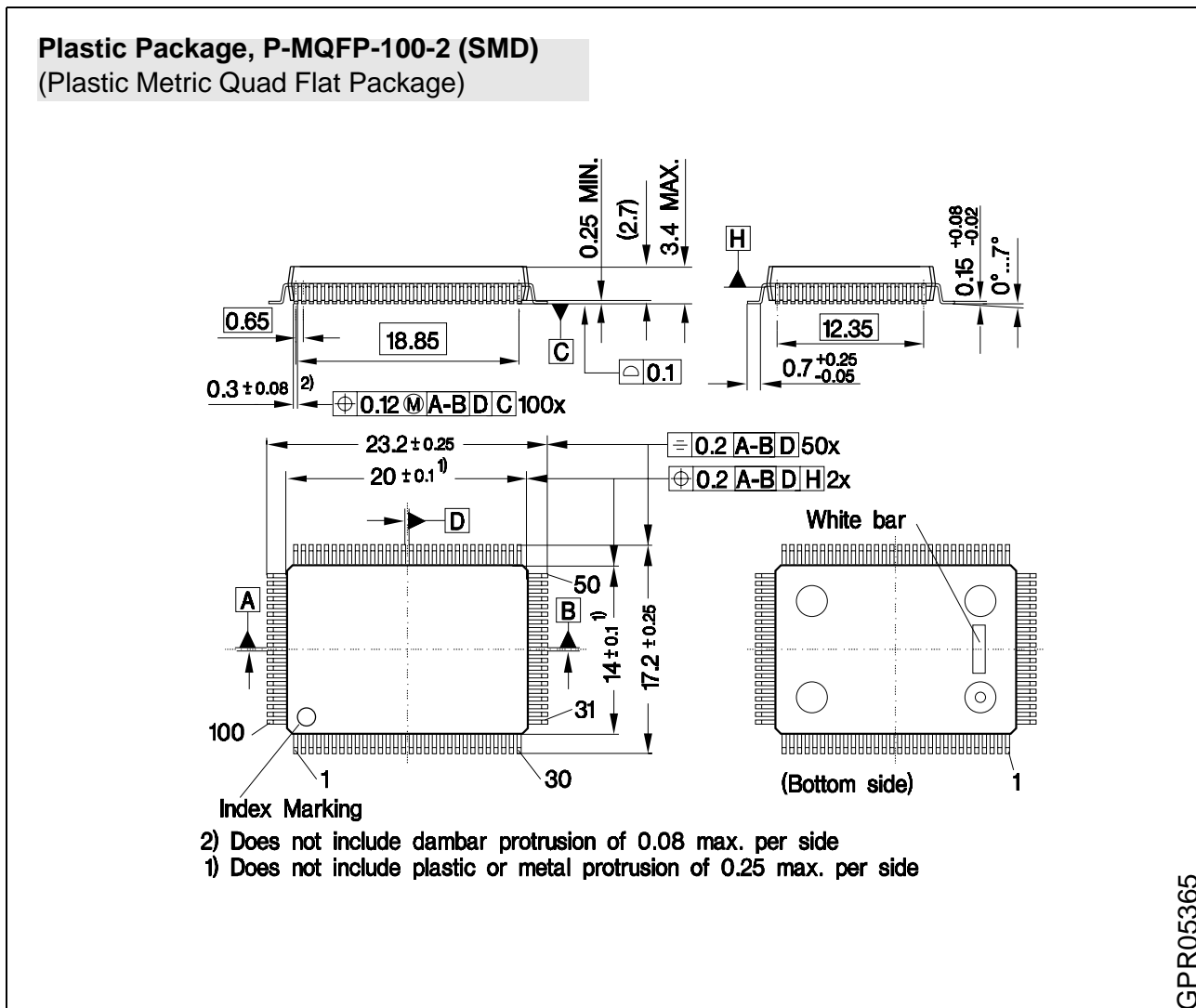
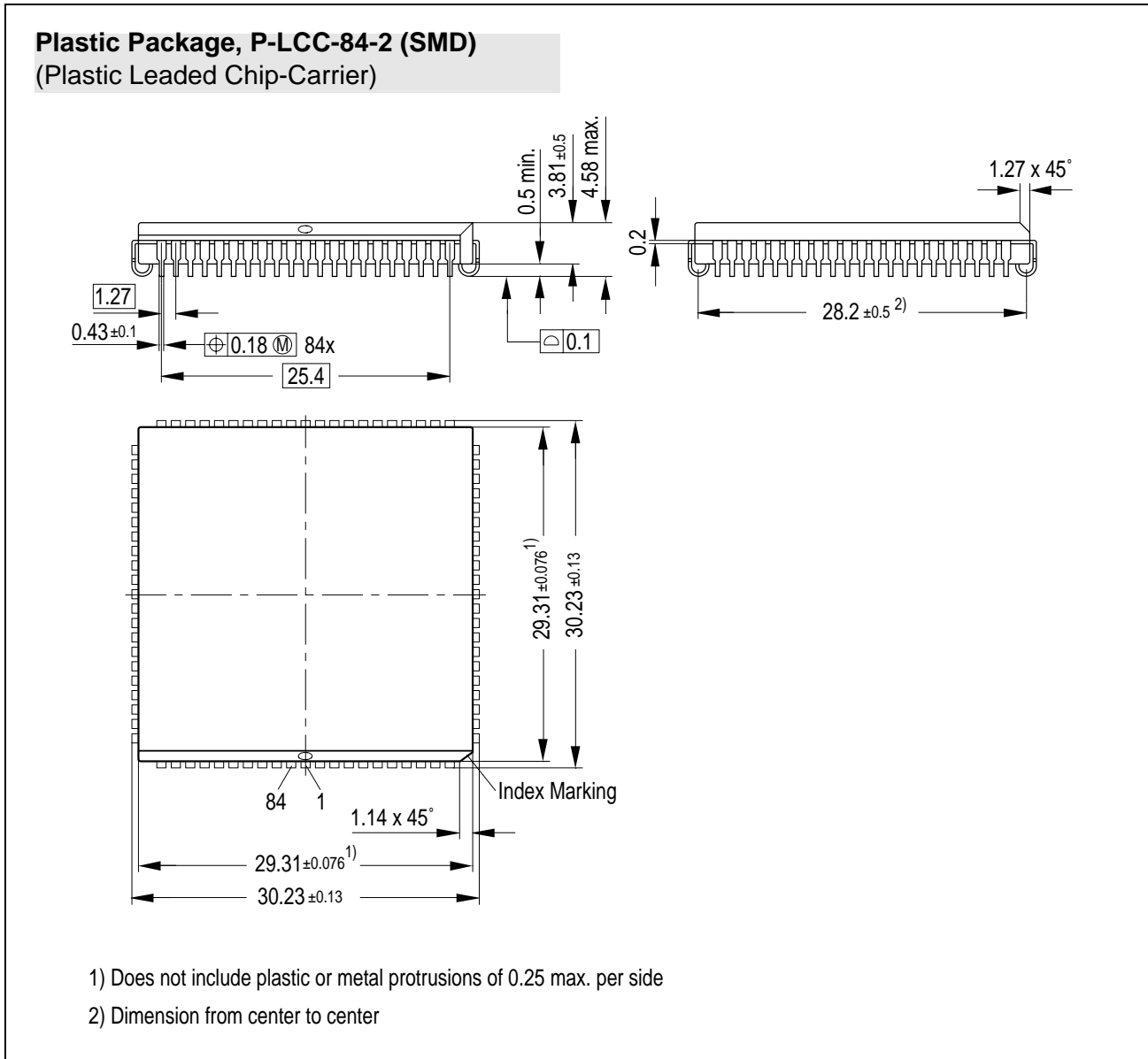


Figure 37  
 P-LCC-100-2 Package Outlines



**Figure 38**  
**P-LCC-84-2 Package Outline**

**Sorts of Packing**

Package outlines for tubes, trays etc. are contained in our Data Book "Package Information"

SMD = Surface Mounted Device

Dimensions in mm

